

VA11

Flow Computer for Steam, Heat, Gas, Liquids



Description:

The VA11 Flow Computer satisfies the instrument requirements for a variety of flowmeter types in liquid, gas, steam and heat applications. Multiple flow equations are available in a single instrument with many advanced features.

The alphanumeric display offers measured parameters in easy to understand format. Manual access to measurements and display scrolling is supported

The versatility of the Flow Computer permits a wide measure of versatility within the instrument package. The various hardware inputs and outputs can be "soft" assigned to meet a variety of common application needs. The user "soft selects" the usage of each input/output while configuring the instrument. Consider the following illustrative examples.

The isolated analog output can be chosen to follow the volume flow, corrected volume flow, mass flow, temperature, pressure, or density by means of a menu selection. Most hardware features are assignable by this method.

The user can assign the standard RS-232 Serial Port for external data logging, transaction printing, or for connection to a modem for remote meter reading.

A Service or Test mode is provided to assist the user during start-up system check out by monitoring inputs and exercising outputs. The system setup can also be printed.

Specifications:

Environmental

Operating Temperature: 0 to +50 C
Storage Temperature: -40 to +85 C
Humidity : 0-95% Non-condensing
Materials: UL, CSA, VDE approved

Approvals: CE Approved Light Industrial, UL/CSA Pending

Display

Type: 2 lines of 20 characters
Types: Backlit LCD and VFD ordering options
Character Size: 0.3" nominal
User selectable label descriptors and units of measure

Keypad

Keypad Type: Membrane Keypad
Keypad Rating: Sealed to Nema 4
Number of keys: 16
Raised Key Embossing

Features

- "EZ Setup"- Guided Setup for First Time Users
- Liquid, Gas, Steam and Heat Flow Equations
- Utility Metering
- Menu Selectable Hardware & Software Features
- Internal Data Logging Option
- Isolated Pulse and Analog Outputs Standard
- RS-232 Port Standard, RS-485 Optional Windows™ Setup Software
- NX19 Gas Equations, Stacked DP Transmitters
- DDE Server & HMI Software Available
- Remote Metering by Wireless or Modem and TROLLink Remote Metering Software Available

Enclosure

Enclosure Options: Panel, Wall, Explosion Proof
Depth behind panel: 6.5" including mating connector
Type: DIN
Materials: Plastic, UL94V-0, Flame retardant
Bezel: Textured per matt finish
Equipment Labels: Model, safety, and user wiring

NX-19 Compressibility Calculations

Temperature	-40 to 240 F
Pressure	0 to 5000 psi
Specific Gravity	0.554 to 1.0
Mole % CO2	0 to 15%
Mole % Nitrogen	0 to 15%

Power Input

The factory equipped power options are internally fused. An internal line to line filter capacitor is provided for added transient suppression. MOV protection for surge transient is also supported

Universal AC Power Option:

85 to 276 Vrms, 50/60 Hz
Fuse: Time Delay Fuse, 250V, 500mA

DC Power Option:

24 VDC (16 to 48 VDC)
Fuse: Time Delay Fuse, 250V, 1.5A
Transient Suppression: 1000 V

Flow Inputs:

Flowmeter Types Supported:

Linear Flowmeters- Magnetic, Turbine, Positive Displacement, Vortex
Square Law Flowmeters- Orifice, Venturi, Nozzle, Annubar, Pitot, V-Cone, Target, Wedge
Other Flowmeters- Gilflo, Bypass Shunt

Pulse Inputs:

Number of Flow Inputs: one
Input Impedance: 10 kΩ nominal
Trigger Level: (menu selectable)
High Level Input
Logic On: 2 to 30 VDC
Logic Off: 0 to .9 VDC
Low Level Input (mag pickup)
Selectable sensitivity: 10 mV and 100 mV
Minimum Count Speed: 0.25 Hz
Maximum Count Speed: Selectable: 0 to 40 kHz
Overvoltage Protection: 50 VDC
Fast Transient: Protected to 1000 VDC (capacitive clamp)

Analog Input:

Ranges

Voltage: 0-10 VDC, 0-5 VDC, 1-5 VDC

Current: 4-20 mA, 0-20 mA

Basic Measurement Resolution: 16 bit

Update Rate: 2 updates/sec minimum

Automatic Fault detection: Signal over/under-range,
Current Loop Broken

Calibration: Operator assisted learn mode. Learns Zero
and Full Scale of each range

Fault Protection:

Fast Transient: 1000 V Protection (capacitive clamp)

Reverse Polarity: No ill effects

Over-Voltage Limit: 50 VDC Over voltage protection

Over-Current Protection: Internally current limited
protected to 24 VDC

Optional: Stacked DP transmitter 0-20 mA or 4-20 mA

Temperature, Pressure, Density Inputs

The compensation inputs usage are menu selectable for
temperature, temperature 2, pressure, density, steam trap
monitor or not used.

Calibration: Operator assisted learn mode

Operation: Ratiometric

Accuracy: 0.01% FS

Thermal Drift: Less than 100 ppm/C

Basic Measurement Resolution: 16 bit

Update Rate: 2 updates/sec minimum

Automatic Fault detection:

Signal Over-range/under-range

Current Loop Broken

RTD short

RTD open

Transient Protection: 1000 V (capacitive clamp)

Reverse Polarity: No ill effects

Over-Voltage Limit (Voltage Input): 50 VDC

Over-Current Limit (Internally limited to protect input to
24 VDC)

Available Input Ranges

(Temperature / Pressure / Density / Trap Monitor)

Current: 4-20 mA, 0-20 mA

Resistance: 100 Ohms DIN RTD

100 Ohm DIN RTD (DIN 43-760, BS 1904):

Three Wire Lead Compensation

Internal RTD linearization learns ice point resistance

1 mA Excitation current with reverse polarity protection

Temperature Resolution: 0.1°C

Datalogger (optional)

Type: Battery Backed RAM

Size: 64k

Initiate: Key, Interval or Time of Day

Items Included: Selectable List

Data Format: Printer or CSV Access via RS-232 command

Stored Information (ROM)

Steam Tables (saturated & superheated), General Fluid
Properties, Properties of Water, Properties of Air, Natural
Gas

User Entered Stored Information (EEPROM / Nonvolatile RAM)

Transmitter Ranges, Signal Types

Fluid Properties

(specific gravity, expansion factor, specific heat, viscosity,
isentropic exponent, combustion heating value, Z factor,
Relative Humidity)

Units Selections (English/Metric)

RS-232 Communication

Uses: Printing, Setup, Modem, Two Way Pager, Datalogging

Baud Rates: 300, 600, 1200, 2400, 4800, 9600, 19200

Parity: None, Odd, Even

Device ID: 0 to 99

Protocol: Proprietary, Contact factory for more information

Chassis Connector Style: DB 9 Female connector

Power Output: 8V (150 mA max.) provided to Modem or Two
Way Pager

RS-485 Communication (optional)

Uses: Network Communications

Baud Rates: 300, 600, 1200, 2400, 4800, 9600, 19200

Parity: None, Odd, Even

Device ID: 1 to 247

Protocol: ModBus RTU

Chassis Connector Style: DB 9 Female connector

Excitation Voltage

24 VDC @ 100 mA overcurrent protected

Relay Outputs

The relay outputs usage is menu assignable to (Individually for
each relay) Hi/Lo Flow Rate Alarm, Hi/Lo Temperature Alarm,
Hi/Lo Pressure Alarm, Pulse Output (pulse options), Wet Steam
or General purpose warning (security).

(Peak demand and demand last hour optional)

Number of relays: 2 (3 optional)

Contact Style: Form C contacts (Form A with 3 relay option)

Contact Ratings: 240 V, 1 amp

Fast Transient Threshold: 2000 V

Analog Outputs

The analog output usage is menu assignable to correspond
to the Heat Rate, Uncompensated Volume Rate, Corrected
Volume Rate, Mass Rate, Temperature, Density, or
Pressure.

(Peak demand and demand last hour optional)

Number of Outputs: 2

Type: Isolated Current Sourcing (shared common)

Isolated I/P/C: 500 V

Available Ranges: 0-20 mA, 4-20 mA (menu selectable)

Resolution: 16 bit

Accuracy: 0.05% FS at 20 Degrees C

Update Rate: 5 updates/sec

Temperature Drift: Less than 200 ppm/C

Maximum Load: 1000 ohms

Compliance Effect: Less than .05% Span

60 Hz rejection: 40 dB minimum

EMI: No effect at 10 V/M

Calibration: Operator assisted Learn Mode

Averaging: User entry of DSP Averaging constant to
cause a smooth control action

Isolated Pulse output

The isolated pulse output is menu assignable to Uncompensated
Volume Total, Compensated Volume Total, Heat Total or Mass
Total.

Isolation I/O/P: 500 V

Pulse Output Form (menu selectable): Open Collector NPN or
24 VDC voltage pulse

Nominal On Voltage: 24 VDC

Maximum Sink Current: 25 mA

Maximum Source Current: 25 mA

Maximum Off Voltage: 30 VDC

Saturation Voltage: 0.4 VDC

Pulse Duration: User selectable

Pulse output buffer: 8 bit

Real Time Clock

The Flow Computer is equipped with either a super cap or a
battery backed real time clock with display of time and date.

Format: 24 hour format for time

Day, Month, Year format for date

Daylight Savings Time (optional)

Fig. 1: Standard Dimensions

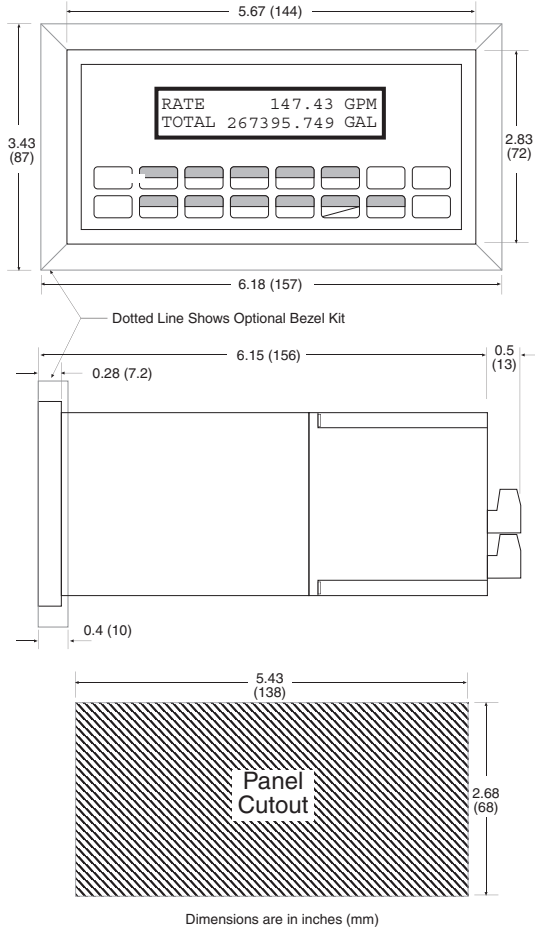
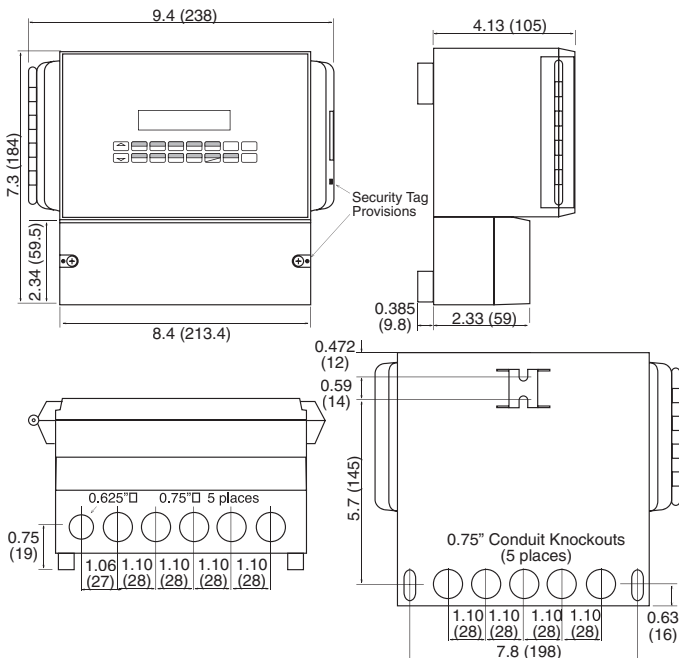

Fig. 2: Wall Mount ("W" mounting option) Dimensions



Terminal Designations

1	DC OUTPUT	DC (+)	DC (-)	23	AC LINE	AC LINE	24	POWER IN
2	PULSE IN	Vin (+)	lin (+)	2	ANALOG OUTPUT 1 (+)	ANALOG OUTPUT 2 (+)	ANALOG OUTPUT COMMON (-)	
3	-----			3				
4	COMMON			4				
5	RTD EXCIT (+)	TEMPERATURE		5				
6	RTD SENS (+)	IN		6				
7	RTD SENS (-)	lin (+)**		7				
8	DC OUTPUT			8				
9	RTD EXCIT (+)	PRESSURE		9				
10	RTD SENS (+)	(TEMP 2)		10				
11	RTD SENS (-)	IN		11				
12	PULSE OUTPUT (+)			12				
13	PULSE OUTPUT (-)			13				
14	ANALOG OUTPUT 1 (+)			14				
15	ANALOG OUTPUT 2 (+)			15				
16	ANALOG OUTPUT COMMON (-)			16				
17	NO			17	COM RLY1			
18	COM RLY1			18	NC			
19	NC			19	COM RLY2			
20	NC			20	NO			
21	COM RLY2			21				
22	NO			22				
23	AC LINE			23				
24	AC LINE			24				

Terminal Layout

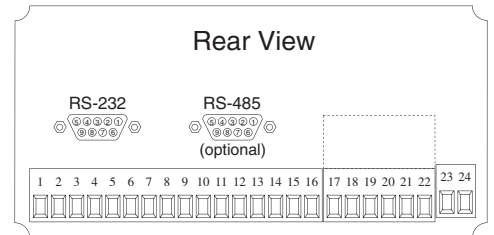

Ordering Information

Example VA11ST2 L 1 0 P M

Series: VA11ST2 = Flow Computer

Display Type: L = LCD, V = VFD

Input Power: 1 = 85 to 276 VAC, 3 = 24 VDC (16 to 48 VDC)

Network Card: 0 = None, 1 = RS485/Modbus (optional 2nd COM port)

Mounting: P = Panel Mount (see Fig. 1), W = NEMA 12/13 Wall Mount w/ Clear Cover (see Fig. 2)

Options:

- 1 = Peak Demand
- 2 = AGA NX-19 calculation for natural gas
- 3 = Three Relays
- 4 = Stacked DP option
- 5 = Datalogger option (consult factory)
- 6 = Stack Emissions Controller option
- 7 = Manifold Flowmeter Controller option
- 9 = 3 Relay Super Chip (options 1, 2, 4, 6, 7)
- 10 = 2 Relay Super Chip (options 1, 2, 4, 6, 7)
- 13 = Superchip; 2 relay, Positive heat only
- 14 = Superchip; 3 relay, Positive heat only
- ET = Extended Temperature; -4°F to 131°F (-20°C to 55°C)
- IM = Internal Modem
- M = Modem Power Option
- TB = RS485 Terminal Block for Panel Mount Enclosure
- TU = Translation Utility Disk



USA
 KROHNE Inc.
 7 Dearborn Road
 Peabody, MA 01960
 TEL.: +1-978 535-6060
 FAX: +1-978 535-1720
 e-mail: krohne@krohne.com