

VA15

INSTALLATION & OPERATING INSTRUCTIONS



KROHNE

USA

KROHNE Inc.
7 Dearborn Road
Peabody, MA 01960
TEL.: +1-978 535-6060
FAX: +1-978 535-1720
e-mail: krohne@krohne.com

Proprietary Notice

The information contained in this publication is derived in part from proprietary and patent data. This information has been prepared for the expressed purpose of assisting operating and maintenance personnel in the efficient use of the instrument described herein. Publication of this information does not convey any rights to use or reproduce it or to use for any purpose other than in connection with the installation, operation and maintenance of the equipment described herein.

Copyright 2005
Printed in USA. All Rights Reserved.



WARNING!

This instrument contains electronic components that are susceptible to damage by static electricity. Proper handling* procedures must be observed during the removal, installation, or handling of internal circuit boards or devices.

*Handling Procedure

1. Power to unit must be removed.
2. Personnel must be grounded, via wrist strap or other safe, suitable means, before any printed circuit board or other internal device is installed, removed or adjusted.
3. Printed circuit boards must be transported in a conductive bag or other conductive container. Boards must not be removed from protective enclosure until the immediate time of installation. Removed boards must be placed immediately in protective container for transport, storage, or return to factory.

Comments

This instrument is not unique in its content of ESD (electrostatic discharge) sensitive components. Most modern electronic designs contain components that utilize metal oxide technology (NMOS, CMOS, etc.). Experience has proven that even small amounts of static electricity can damage or destroy these devices. Damaged components, even though they appear to function properly, may exhibit early failure.

CONTENTS

1. INTRODUCTION

1-1 General Description.....	1
1-2 Typical Application.....	1
1-3 Principles of Operation	1
1-4 STD PRE and EZ PRE Operation Modes	3
1-5 Specifications	4
1-6 Dimensions.....	5

2. INSTALLATION

2-1 Receipt of Equipment	6
2-2 Return Shipment.....	6
2-3 Panel Mounting.....	6
2-4 Electrical Connections	6
2-5 Wiring Connections and Diagrams	7

3. OPERATION

3-1 Front Panel Operation	8
3-2 VER 8.7 Programming.....	9
3-3 VER 8.7 K-Factor Programming.....	9
3-4 Software Version 8.7 Programming Flow Chart	10
3-5 VER 12.0 Programming.....	11
3-6 VER 12.0 16 Point Linearization Notes	11
3-7 Software Version 12.0 16 Pt. Programming Flow Chart.....	12
3-8 How to Program.....	13
3-9 Frequently Asked Questions About Setting Up The Batcher.....	13
3-10 Setup Procedure For The Batcher.....	14
3-11 Run Mode	27
3-12 Internal Operation.....	29

4. INPUTS

4-1 Digital Pulse Inputs.....	30
4-2 Analog Inputs.....	30
4-3 DC Power Inputs	32
4-4 AC Power Inputs.....	32

5. OUTPUTS

5-1 Frequency Output.....	32
5-2 Control Outputs	33
5-3 Optional Analog Output	33
5-4 Optional RS232 / RS422 Serial Communications	34

CONTENTS

6. TROUBLE SHOOTING AND MAINTENANCE GUIDE

6-1 Warning Messages.....	34
6-2 Troubleshooting.....	35
6-3 Removing The Case.....	36
6-4 Maintenance.....	36

7. CALCULATING THE K FACTORS

7-1 General.....	36
7-2 Calculating the K Factors	37
7-3 Calculating 16 Point K Factors	39

8. SERIAL COMMUNICATIONS

8-1 Unit Code.....	40
8-2 Baud Rate.....	40
8-3 Parity	40
8-4 RS232 Electrical Requirements.....	40
8-5 RS232 Card Wiring.....	41
8-6 RS422 Electrical Requirements.....	41
8-7 RS422 Card Wiring.....	42
8-8 Strobe Input Electrical Requirements	42
8-9 Strobe Wiring.....	43
8-10 Serial Interface Operation.....	43
8-11 Strobe Address Operation.....	45

9. Programming Worksheet	46
---------------------------------------	-----------

SECTION 1 INTRODUCTION

1-1 General Description

Sections 1 through 8 of this manual describe the wiring, programming and functionality of the standard Batch controller. Section 9 describes the wiring, programming and functionality of Batch controllers with software version 8.7 (Option 6). Software version 8.7 incorporates Remote Start, Stop & Reset with EZ PRE (easy preset). EZ PRE is a useful tool for applications that require frequent changes to the Preset amount.

The Batch controller uses the following software versions:

VER 8.7 (Basic unit; Remote Start, Stop & Reset with EZ PRE "Easy Preset")

VER 12.0 (Option 4; 16 point linearization)

1-2 Typical Application

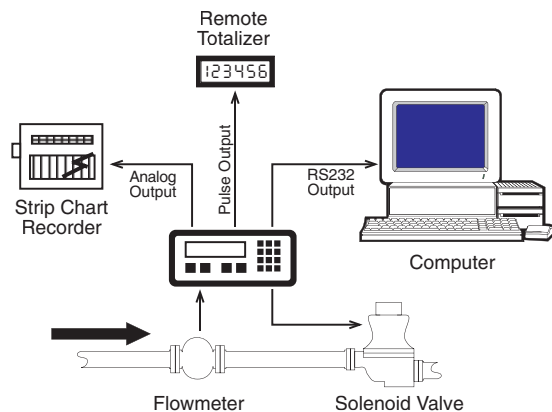

The above application involves liquid flow. The start button is pushed and the Batcher receives pulses from the flowmeter. The pulses are scaled by the K Factor and sent out via the pulsed output to an external counter. The Analog output is directed to a strip chart recorder which gives a hardcopy of the rate. As the Prewarn is reached, the control valve partially closes. When the final Preset is reached the valve shuts down completely. At any time the flow can be suspended by hitting the stop button. Through the serial communications, a computer keeps a record of the daily events.

1-3 Principles of Operation

Presets

When the start button is pushed, two relays engage simultaneously to start flow. When the prewarn number is reached, one relay drops out. When the preset number is reached, the other relay drops out. The user may enter the two numbers when setting up the batch counter. The prewarn is set a certain number of counts less than the preset number. If the prewarn is set larger than the preset, the message "PREWRONG" will appear on the display.

Ratemeter

Accurate to 5 1/2 digits (± 1 display digit). The ratemeter can be programmed to accept almost any number of pulses per unit of measurement, sample from 2 to 24 seconds maximum, and auto range up to 6 digits of significant information. The ratemeter with a K Factor of 1 displays the rate of pulses per second. Simply dial in the proper K Factor to display in minutes, hours or other units of measurement. Press the C button, while the unit is displaying the batch, to display the rate; 'R' is displayed on the left side of the display.

K Factor

The K Factor is used to convert the input pulses or analog input into workable units. The 8 digit K Factor is a divider with a range of 0.00011 to 99999999 (the decimal point may be keyed into any position). Separate K Factors may be entered into the count and rate sections of the Batcher. Thus, you may batch in gallons and display rate in liters per hour. The maximum factored count speed is 20000 Hz. The maximum factored rate is 7 digits.

16 Point Linearization (Optional)

This option extends the accurate range by allowing users to dial in different K Factors for different input rates. This option may be used with digital or analog inputs. (See Section 7-3.)

1-3 Principles of Operation (continued)

Counter

The maximum count is 99999999. In the setup mode choose "RO" (Reset to Zero) for adding (count up) operation or "SP" (Set to Preset) for subtracting (count down) operation. At any time, the display can be made to flash the Grand Total by pressing the ENT button while in the run mode. Activating the CLR button while the Grand Total is flashing, resets the Grand Total counter.

Lockout

Unauthorized front panel changes can be prevented by entering a user selected, four digit code, in the "Lockout" mode. The status of the unit can be observed but "LOCK ON" appears if changes are attempted. Entering the code again returns the unit to "LOCK OFF" status.

Analog Output (Optional)

The Analog Output option is available on all units except those with **Square Law** inputs. Controlled by an Open Collector transistor, it gives a 4 to 20mA (or 0-20mA) output which corresponds to predefined rate or total readings. In the Setup mode the user is prompted to set the low and high (4 to 20 mA) values and also decide if the analog signal will correspond to the ratemeter or totalizer.

A sinking driver generates a linear current across the user's external device (such as a strip chart recorder, PLC, computer, external meter, etc). The Batcher can supply the 24 VDC to power the current loop. (Connect pin 15 to 13, Pin 16 is now +24 VDC with respect to pin 12.) Connect Pin 16 to the + DC side of the external device and connect Pin 3 to -DC side of the external device.

Frequency out

The Batcher generates a pulse out for each factored count. An NPN transistor output (Pin 2), can drive external devices at rates of 10, 200, 2000 or 20000 counts per second as selected through the keypad menu. If the K Factor scaled inputs generate pulses faster than the output speed selected, an internal buffer will store up to 9,999 counts before "DATA LOST" flashes on the screen. This indicates that the counts being totaled and the scaled outputs may be incorrect. Note that all counts stored in the internal buffer will be pulsed out at the selected frequency even if the counter is reset.

Outcard (Optional)

RS232 or RS422 serial two way communications are available. Up to 15 units can be linked together in parallel and addressed separately to transmit unit status or accept new set points in the standard ASCII format. Baud rates of 300, 600, 1200, 2400, 4800 or 9600 as well as choice of odd, even, space, or mark parity can be selected by keypad control.

1-4 STD PRE and EZ PRE Operation Modes

STD PRE and EZ PRE Operation Modes

Version 8.7 of the batcher software allows the user to choose between STD PRE (Standard Preset) and EZ PRE (Easy Preset) operation modes. STD PRE operation is well suited for batch amounts that do not change, since the program mode must be entered to change the preset and the batch count must be cleared before starting a new batch. EZ PRE has been designed for users who frequently change the batch amount. During EZ PRE operation, the preset can be viewed and changed without entering the program mode and another batch can be started without resetting the unit.

Note: *Before a batch is started and after a batch is complete, the unit will continue to totalize all inputs.*

Note: *EZ PRE is not available on units with 16 Point Linearization.*

Using STD PRE

Programming

Select STD PRE - Go into the Program Mode and select STD PRE in the PRE TYP sub menu.

Set the PRESET and PREWARN - Go into the Program Mode and enter the desired values for the PRESET and the PREWARN.

Program the Counter - Go into the Program Mode and set up the counter in the COUNT sub menu.

Operation

Start a Batch - In the Run Mode, reset the total by pressing "CLR", then press "A" to start. When started, both relays energize and the counter begins to count. When the batch is complete, the relays drop out and the unit displays the amount that was batched (0 if in Set to Preset mode).

Stop a Batch - Press "B", to temporarily stop process by de-energizing the PRESET and PREWARN relays. Press start, "A", to continue process.

Repeat a Batch - In the Run Mode, reset the total and press the start button.

Change the Batch Size - Go to the Program Mode and enter new PRESET and PREWARN values.

Using EZ PRE

Programming

Select EZ PRE - Go into the Program Mode and select EZ PRE in the PRE TYP sub menu.

Set the PRESET and PREWARN - Go into the Program Mode and enter the desired values for the PRESET and the PREWARN.

Program the Counter - Go into the Program Mode and set up the counter in the COUNT sub menu.

Operation

Start a Batch - In the Run Mode, press "A" to start. When started, both relays energize and the counter begins to total. When complete, the relays drop out and the display flashes the current PRESET value.

Stop a Batch - Press "B", to temporarily stop process by de-energizing the PRESET and PREWARN relays. Press start, "A", to continue process.

Repeat a Batch - Press the start button.

Change the Batch Size - With the current PRESET flashing on the display, type a new number using the keypad. This number becomes the PRESET.

Display Batch Total or Rate - With the current PRESET flashing, press "ENT" to place the PRESET value in memory and use the "C" button to toggle between the Batch Total and the Rate.

1-5 Specifications

Housing:

High impact plastic case with NEMA 4X front panel.

Dimensions:

See Section 1-5, Page 4.

Display:

8 Digit, 0.55" High, 15 Segment, Red Orange, LED.

Input Power:

A: 110 VAC \pm 15% or 12 to 27 VDC

B: 220 VAC \pm 15% or 12 to 27 VDC

NOTE: AC Inputs are internally fused with a 160mA slow blow fuse.

Current:

Maximum 280 mA DC or 5.3 VA at rated AC voltage.

Output Power:

(On AC powered units only): +12 VDC at 100 mA. Separate Isolated 12 VDC at 100 mA to allow \pm 12 VDC or +24 VDC, regulated \pm 5% worst case.

Temperature:

Operating: +32°F (0° C) to +130 ° F (+54° C)

Storage: -40°F (-40° C) to +200 ° F (+93° C)

(Extended operating temperature range available, consult factory)

Memory:

EEPROM stores all program, display mode and count data for a minimum of 10 years if power is lost.

Reset

Front push button: "CLR" resets displayed number and control output.

Remote Input (Terminal 5): Open or 0 to 1 VDC (low), 3 to 30 VDC (high), 10K ohm input impedance to ground. Minimum pulse on / off time 5 msec.

Accuracy over full temperature range:

Analog - Zero error: \pm 0.175% full scale max.

Overall error: \pm 0.5% full scale max.

Digital - 100% (within specified voltage ranges)

Pulse Inputs:

3A: Standard. High impedance pulse input. Open or 0 to 1 VDC (low), 3 to 30 VDC (high), 10K ohm input impedance. 20 KHz maximum speed (min. on / off 25 usec).

3B: Same as 3A except 4.7 K ohm pull up resistor to +5 VDC with respect to Terminal 12.

Analog Inputs:

The current or voltage input is converted to a highly linear 0 to 10 KHz frequency. This frequency can then be scaled by 8 digit K-factors to display rate or count in the appropriate engineering units.

5A: 4-20 mA; 250 Ω input impedance.

5B: 0-20 mA; 250 Ω input impedance.

5C: 1-5 VDC; 15 K Ω input impedance.

5D: 0-5 VDC; 15 K Ω input impedance.

5E: 0-10 VDC; 15 K Ω input impedance.

6A: Square Law: 4-20 mA; 250 Ω input impedance.

1-5 Specifications (continued)

Factored Output:

One pulse per each factored count

Sinking (NPN Transistor)

Open Collector sinks 250 mA maximum to 1 volt maximum from 30 VDC maximum

Internal buffer: 9999 pulses

Output speed: user selectable (see table below)

Speed (Hz)	10	200	2000	20000
Min. on/off (msec)	47.5	2.0	0.2	0.013

Analog output:

(Not available with 4-20 mA, Square Law input type)

4-20 mA (or 0-20 mA)

Sinking, (NPN transistor), Open Collector

Compliance voltage: 3-24 VDC, non-inductive

Accuracy: ± 100 μ A worst case

Update Rate: Follows ratemeter

Control Outputs:

SPDT Relays

Contact rating: 10 A 120/240 VAC or 28 VDC.

NPN Transistor Output

Open Collector sinks maximum of 100 mA from 10 VDC when active

Note: 10 VDC is provided at transistor outputs through the relay coils. If current greater than 2 mA is drawn, the relay will remain energized. Applying greater than 10 VDC may destroy the unit. The transistor will sink 100 mA in the "ON" state with relays installed.

1-6 Dimensions

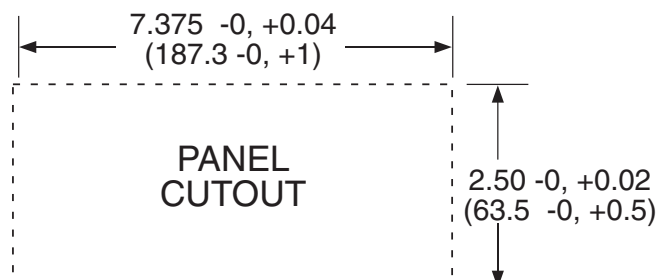
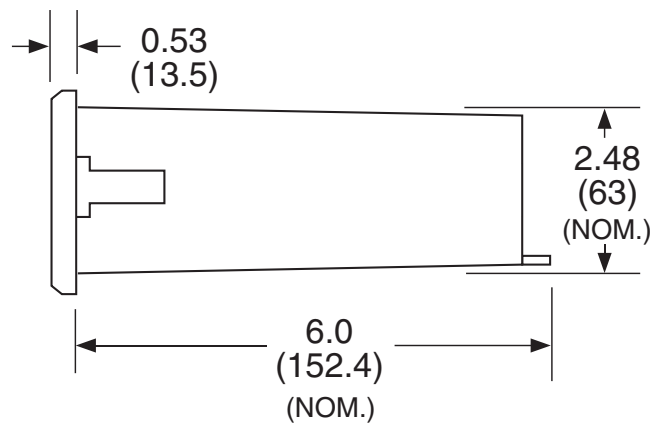
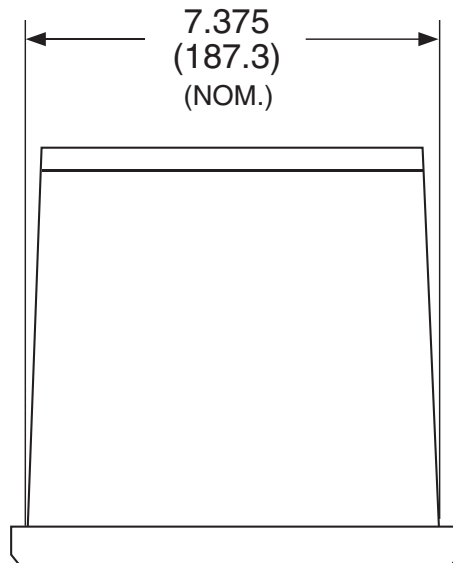
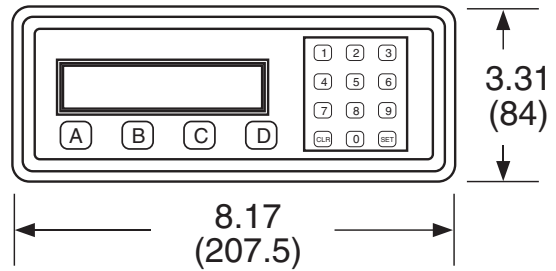

All Dimensions in inches (mm)

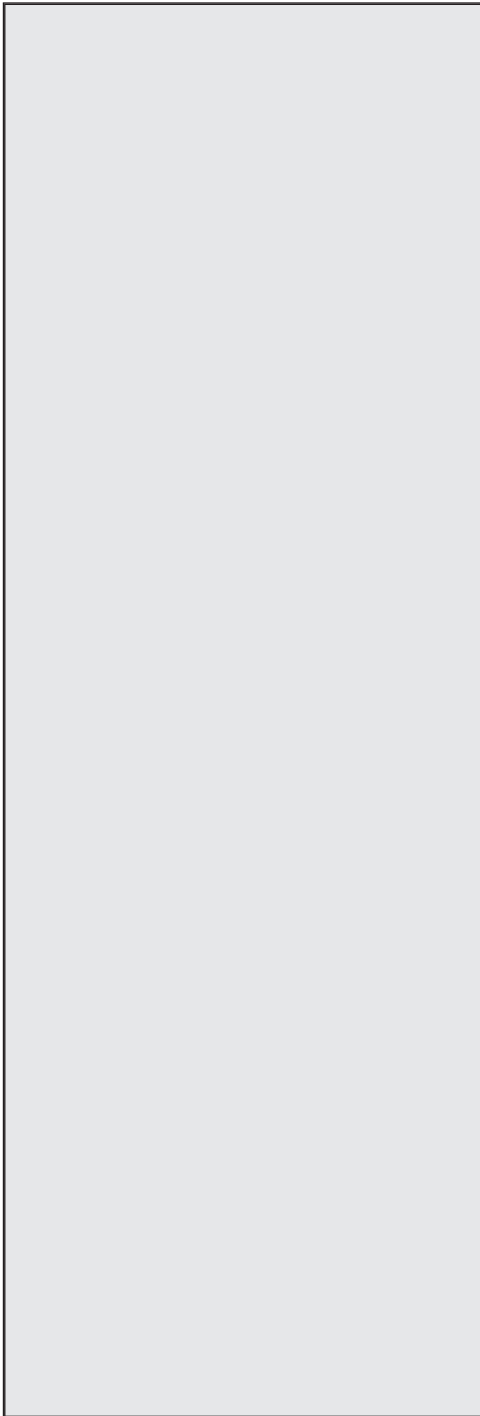

Full Size Panel Cutout Template
(copy before using)

2-1 Receipt of Equipment

When the equipment is received, the outside packing case should be checked for damage incurred during shipment. If the packing case is damaged, the local carrier should be notified at once regarding his liability. A report should be submitted to the factory.

Carefully remove the equipment from the packing case and inspect for damaged or missing parts.

2-2 Return Shipment

Do not return assembly or part with out a Return Material Authorization. The RMA is obtained by calling your local distributor.

2-3 Panel Mounting

The controller should be located in an area with a clean, dry atmosphere which is relatively free of shock and vibration. The Batcher is installed in a 7.365" (187 mm) wide by 2.495" (63.4 mm) high panel cutout. To mount the controller proceed as follows:

- a. Prepare the panel opening.
- b. Slip the gasket (provided) over the rear of the counter case and slide it forward until it engages the inner surface of the front bezel.
- c. Install the screws (provided) in the mounting brackets and insert in the holes located on both sides of the Batcher.
- d. Tighten the screws firmly to attach the counter bezel to the panel.

2-4 Electrical Connections (Reference Figures 2-1 to 2-3)

All connections are completed at terminal blocks located at the rear of the case. Make sure all power is disconnected before making any electrical connections. In cases where cables are situated in areas with heavy electrical fields,

2-4 Electrical Connections (continued)

shielding is required for maximum noise immunity. One end of the shielding should be connected to earth ground. Relays or inductive coils connected to or located in the immediate area should be arc suppressed with appropriate diodes, MOV's or resistor capacitor networks.



Caution: An external fuse is required:

DC Power: 0.5 Amp
AC Power: 0.125 Amp

2-5 Wiring Connections and Diagrams

- 1 - Not Used
- 2 - Scaled Pulse Output O.C.
- 3 - Analog Output
- 4 - Input A (Pulse/Analog)
- 5 - Remote Stop/Reset Input
- 6 - Not Used
- 7 - Not Used
- 8 - Not Used
- 9 - Not Used
- 10 - Remote Start Input
- 11 - Ground (-DC), Input Common
- 12 - Ground (-DC), Input Common
- 13 - +12 Volts Out
- 14 - DC Power In (12 - 27 VDC)
- 15 - Isolate -12 Volts
- 16 - Isolate +12 Volts
- 17 - AC In
- 18 - AC In
- 19 - Prewarn Transistor O.C.
- 20 - Preset Transistor O.C.

<input type="checkbox"/> R1-N.O	Preset
<input type="checkbox"/> R2-N.C.	
<input type="checkbox"/> R3-Common	Prewarn
<input type="checkbox"/> R4-N.O	
<input type="checkbox"/> R5-N.C.	
<input type="checkbox"/> R6-Common	

Figure 2-1 Terminal Block Connections

2-5 Wiring Connections and Diagrams

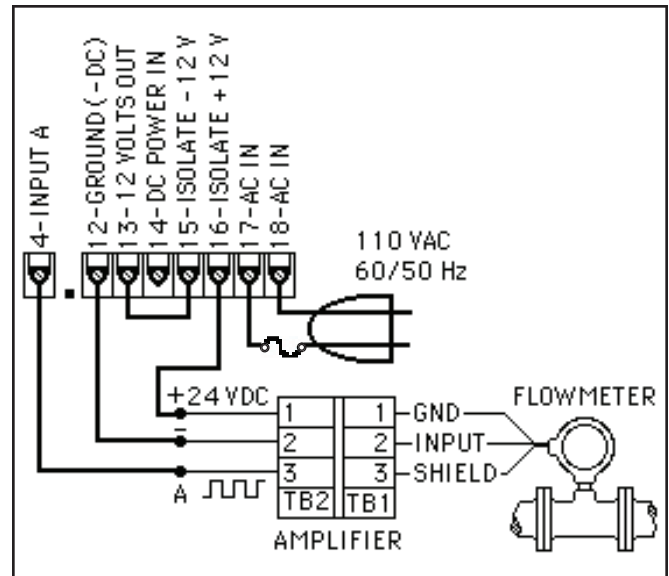

Figure 2-2
Typical Digital Wiring Connections

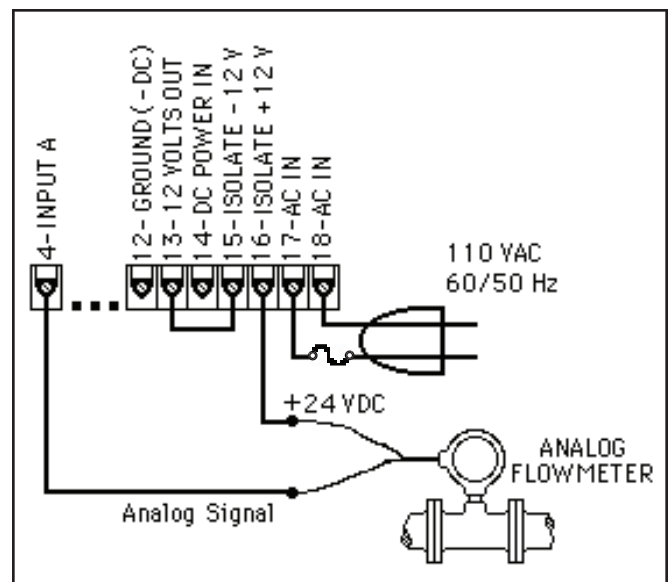
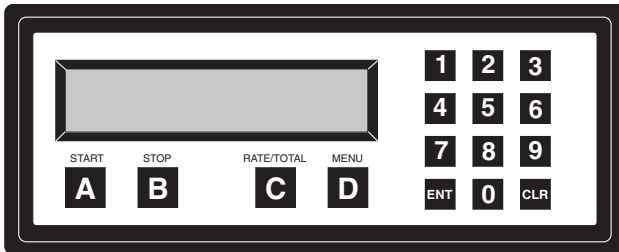

Figure 2-3
Typical Analog Wiring Connections

3-1 Front Panel Operation

**A**

START - Pressing "A", starts the process by energizing the PRESET and PREWARN relays. Press "CLR" to reset Batch Total before starting new batch.

B

STOP - Pressing "B", will temporarily stop the process by de-energizing the PRESET and PREWARN relays. Use START to continue the process from where it stopped.

C

RATE/TOTAL - Pressing "C" toggles between rate and total count displays. The rate display has an "R" on the left side of the screen.

D

MENU - Pressing "D" takes the unit out of the Run Mode and into the Programming Mode (See Programming, Page 43 and 45). "D" is also used make to some programming selections.

ENT

ENT - With Count showing in the Run Mode, pressing "ENT" displays the Grand Total, which begins flashing on the screen. Press "ENT" again to return to the Count. In the Programming Mode, "ENT" is used to accept a selection (See Programming, Page 43 and 45).

CLR

CLR - When the count total is displayed, pressing "CLR" will reset the counter to 0 or to Preset A depending on how it was programmed. When the Grand Total is displayed, pressing "CLR" will reset it to 0. When the Preset or Program Mode values are displayed, pressing "CLR" will reset them to 0, so that new values can be entered.

Weighted Averaging

Version 8.7 of the batcher software includes weighted averaging of the rate display. Weighted averaging is not available on units with 16 Point Linearization.

Weighted averaging can be used to create a more stable display when the rate input is fluctuating. A weight, "W", from 00 to 99 is applied to the old rate data before the new rate data is sent to the display. The following equation is used:

$$\text{Rate Display} = \frac{(\text{Old Data} \times W + \text{New Data})}{(W + 1)}$$

W = Weight (00-99)

If a weight of 00 is used, the new rate data will go directly to the display without being averaged. If a number other than 00 is entered for the weight, then the new data will be averaged with the old data before being sent to the display. Higher weight numbers will create a more stable rate display. Small rate changes will be more noticeable when lower weight numbers are used.

Programming Weighted Averaging

1. In the Program Mode, got to the RATE sub menu and program the K-FACTOR, the WINDOW, and the SIG FIG parameters.
2. When the display shows WEIGHTXX (XX represents the current WEIGHT value), either accept the current value and return to the Run Mode by pressing "ENT" or clear the current value by pressing "CLR".
3. If the current value was cleared, the display shows WEIGHT00. Using the keypad, enter a new WEIGHT value from 00 to 99. Press "ENT" to accept the new value and return to the Run Mode.

Remote Start, Stop, and Reset

A 4 to 30 VDC positive pulse will activate these inputs. Remote Start, Stop, and Reset is not available on units ordered with the Control Input option 7A (4-20 mA In, 4-20 mA Out).

START (Pin 10): When activated, the unit will START as described in Front Panel Operation.

STOP/RESET (Pin 5): When activated, the unit will STOP (If the unit is started and the batch is not complete). A second pulse to pin 5 will reset the counter (When the unit is stopped or when the batch is complete). If pin 5 is held high (4 to 30 VDC), the display will flash "STOPPED" and any start inputs will be inhibited.

3-2 VER 8.7 Programming

Overview:

This Section of the manual provides an outline of programming procedures for the batcher software version 8.7. Detailed descriptions and programming instructions for this unit are available in previous sections of this manual. Page number references are included to help you find related information in this manual.

Programming Procedures:

Enter Program Mode - Press the MENU button, "D", in the Run Mode.

Choosing a Sub Menu - Once in the Program Mode, continue pressing the "D" button until the desired Sub Menu is displayed. Press "ENT" to enter the selected Sub Menu.

Making a Selection - An arrow, "↓", appearing over only the "D" button indicates that "D" is used to change the selection. When an arrow appears over "B" and "D", one must be selected.

Entering a Value - The keypad is used to enter a number. Use the "D" button to enter a decimal. (Ex: 34.5 would be entered by pressing "3", "4", "D", and "5")

Accept a Value or Selection - Press "ENT" to accept the value and go to next step.

Exit Program Mode - Program or skip each step of one of the menus to return to the Run Mode. Pressing "ENT" allows a step to be skipped without changing its value.

Key to Programming Flow Chart:

Display - This box represents the unit's display. In the Run Mode, the flow rate, the batch total, or the grand total will be displayed.

XX **Current Value** - The number that is currently programmed for that step. It must be cleared (CLR button) before entering a new value.

00 **No Value** - Indicates that programmed value for that step has been cleared, and a new number may be entered.



Keypad - Use the front panel keypad to enter a value or select a decimal point location for this step.

3-3 VER 8.7 K-Factor Programming

(See Programming Flow Chart, Page 10)

(For information on entering a K-Factor on a unit with 16 Point Linearization, see **16 Point Linearization Notes**, page 11) The K-Factor is usually provided in pulses per unit, and will have to be modified before entering it into the unit. On most flowmeters, the K-Factor is stamped on the nameplate. (see section 7 for Calculating K-Factors)

Count K-Factor:

The Count K-Factor must be modified to allow for the decimal point location chosen in the "DEC LOC" step.

$$\frac{\text{K-Factor}}{\text{DPF}} = \text{Count K-Factor}$$

DPF - The Decimal Point Factor is a divider to compensate for the displayed decimal point.

DPF Table

DPF	Decimal	DPF	Decimal
1	XXXXXX.	1000	XXX.XXX
10	XXXXX.X	10000	XX.XXXX
100	XXXX.XX	100000	X.XXXXX

Rate K-Factor:

The Rate K-Factor must be modified to display the correct volume per time unit. The Rate K-Factor is not affected by the decimal point location selected in the Count menu. The decimal point displayed by the Rate Meter floats according to the significant figure setting used in the SIG FIG step.

$$\frac{\text{K-Factor}}{\text{TF}} = \text{Rate K-Factor}$$

TF - The Time Factor is a divider to adjust the time units that the Rate Meter shows.

TF Table

TF	Time Units	Rate Display
1	Seconds	Units per Second
60	Minutes	Units per Minute
3600	Hours	Units per Hour

3-5 VER 12.0 Programming

(Unit with 16 Point Linearization)

Overview:

This Section of the manual provides an outline of programming procedures for the software version 12.0. Detailed descriptions and programming instructions for this unit are available in the following sections of this manual. Page number references are included to help you find related information in this manual.

Programming Procedures:

Enter Program Mode - Press the MENU button, "D", in the Run Mode.

Choosing a Sub Menu - Once in the Program Mode, continue pressing the "D" button until the desired Sub Menu is displayed. Press "ENT" to enter the selected Sub Menu.

Making a Selection - An arrow, "↓", appearing over only the "D" button indicates that "D" is used to change the selection. When an arrow appears over "B" and "D", one must be selected.

Entering a Value - The keypad is used to enter a number. Use the "D" button to enter a decimal. (Ex: 34.5 would be entered by pressing "3", "4", "D", and "5")

Accept a Value or Selection - Press "ENT" to accept the value and go to next step.

Exit Program Mode - Program or skip each step of one of the menus to return to the Run Mode. Pressing "ENT" allows a step to be skipped without changing its value. (Note: "B" or "D" must be pressed on the first step in the DEV TYP menu)

3-6 VER 12.0 16 Point Linearization Notes

(See Programming Flow Chart, Page 12)

A K-Factor and a Frequency must be entered for at least three points on a unit with Linearization.

Linearization K-Factor: The K-Factor for each Linearization point must be modified to allow for the display decimal point location chosen in the "DEC LOC" step of the "DEV TYP" menu. Modify each K-Factor using the following equation:

$$\frac{\text{K-Factor}}{\text{DPF}} = \text{Linearization K-Factor}$$

DPF - The Decimal Point Factor is a divider to compensate for the displayed decimal point.

DPF Table

DPF	Decimal	DPF	Decimal
1	XXXXXX.	1000	XXX.XXX
10	XXXXX.X	10000	XX.XXXX
100	XXXX.XX	100000	X.XXXXX

Calculating K-Factors and Frequencies: If a Linearization table is not available, the K-Factor and the frequency for each point can be calculated using the Test Mode on the unit. Refer to Section 7-3.2, Test Mode Operation and K-Factor Calculation, on page 37.

Entering K-Factors and Frequencies: Refer to Section 7-3, Calculating 16 Point K-Factors, on page 37 and the programming step listing on page 23.

Key to Programming Flow Chart:

 **Display** - This box represents the unit's display. In the Run Mode, the flow rate, the batch total, or the grand total will be displayed.

XX **Current Value** - The number that is currently programmed for that step. It must be cleared (CLR button) before entering a new value.

00 **No Value** - Indicates that programmed value for that step has been cleared, and a new number may be entered.

Keypad - Use the front panel keypad to enter a value or select a decimal point location for this step.



3-8 How to Program

The initial programming of the unit is accomplished by first depressing the MENU button. After pressing the MENU button once, the display will read preset. To cycle to the next control parameter option, merely press the MENU button and Prewarn will appear on the display. If the user does not wish to choose this section of the menu, depress MENU button again and the next control or parameter will appear.

Selection of all MENU control parameters is accomplished through the routine described for Preset.

The following is the sequence for entering a Preset quantity.

1. Depress the Menu D button once. The display will read MENU. After a one second pause the display will read PRESET.
2. Depress the Enter ENT button; the display will flash indicating that you are not in the Run Mode and not displaying the current batch total.
3. If the batch size is satisfactory, depress the ENT button. This value will be entered into memory. Simultaneously, the unit will return to the Run Mode.
4. To change the preset value, depress the CLR button and enter new number. Example: Suppose "250" is the new batch size. Press CLR, then 2, then 5, then 0. When the display holds the desired value, depress the ENT button. The new batch size will be stored in memory and simultaneously the batcher will return to the Run Mode.

3-9 Frequently Asked Questions About Setting Up The Batcher

- Q. Is there any way to backspace if the wrong button is hit by accident?
- A. No, you can depress the CLR button and start entering the number all over again or press ENT repeatedly until back in the Run mode and start over again from there.
- Q. Is there any way to put a decimal point in a number such as a preset or K Factor?
- A. Yes, simply press the D button after the digit that you would like the decimal point. It will appear to the right of the digit.
- Q. Is there any way to enter a negative number for one of the Presets or K Factors?
- A. No, negative values are not allowed.
- Q. Is there any way to ruin the unit or completely erase it by entering a bad number?
- A. No, if a number or entry is not valid the unit will ignore it or flash an error message.
- Q. If the unit does not have serial communications or analog out, does the OUTCARD and ALG OUT sections of the menu still have to be set up?
- A. No, there are default settings from the factory already in the unit. No setup of these menu items is necessary for normal operation.
- Q. Does the Batcher have to be told what type of input it has connected to it?
- A. No, The input signals are conditioned in hardware. This allows the input cards to be interchanged without modifying the software.
- Q. If CLR is not pressed, numbers can still be written over the Presets or K Factors. Will these numbers be accepted if the ENT button is pushed?
- A. No, in order for a Preset or K Factor to be changed, the old number must be cleared out first by depressing the CLR button.

3-10 Setup Procedure For The Batcher

MENU ITEM 1 PRESET

<u>PRESS</u>	<u>DISPLAY</u>
D Menu Button.	PRESET ↓
ENT Enters Preset Routine.	Flashing PRESET number.
CLR Clears out existing PRESET.	0 Flashes.
1 2 3 4 Sample Preset.	1234 PRESET Flashes.
ENT Store new Preset.	Last count, unit now in run mode.
Final Preset is Set.	

MENU ITEM 2 PREWARN

The Prewarn value is the amount before the Preset value that the Prewarn relay will deactivate. For example, if you want the Prewarn relay to drop out 10 counts before the Preset and your Preset is 1234, then set your Prewarn at 10 (not at 1224). Enter a Prewarn of "0" for the Prewarn and Preset relays to activate together. To disable the Prewarn relay, enter the same value for Preset and Prewarn.

<u>PRESS</u>	<u>DISPLAY</u>
D MENU Button.	PRESET ↓
D	PREWARN ↓
ENT Enters Prewarn Routine.	Flashing PREWARN number.
CLR Clears out existing PREWARN.	0 Flashes.
1 2 3 4 Sample Prewarn.	1234 Prewarn Flashes.
ENT Store new Prewarn.	Last count, unit now in Run Mode.
The Prewarn is Set.	

Note: Remember, if the prewarn is a larger number than the preset, then the warning "**PREWRONG**" will flash on the display. Enter a prewarn value that is less than or equal to the preset to clear this warning.

3-10 Setup Procedure For The Batcher (continued)

MENU ITEM 3 PRE TYP

This menu item is used to set up the Preset Type.

<u>PRESS</u>	<u>DISPLAY</u>
D	PRESET ↓
D	PREWARN ↓
D	PRE TYP ↓
ENT	STD PRE ↓ EZ PRE ↓
Press D toggle between selections.	
ENT	Enters displayed selection Run Mode

The PRE TYP is Set.

MENU ITEM 4 COUNT

Setting the Counter

<u>PRESS</u>	<u>DISPLAY</u>
D	PRESET ↓
D	PREWARN ↓
D	PRE TYP ↓
D	COUNT ↓
ENT	K FACTOR
K FACTOR flashes then shows the current K Factor. Note: The K Factor setup is skipped if the unit has 16 Point option. The unit goes directly to R0 SP.	
CLR	0 Flashes.
Clears out existing K FACTOR.	
3 7 D 6	37.6 Flashes.
Sample K Factor, or enter calculated value from notes or worksheet.	

continued on next page

3-10 Setup Procedure For The Batcher (continued)

MENU ITEM 4 **COUNT** (continued)

PRESS



Store new K Factor.

DISPLAY

R0 ↓ SP ↓

RO is Reset to zero. SP is Reset to Preset. This selection determines whether the unit counts up or counts down. If RO is selected (B is pressed), the unit will count in the “up” direction towards the Preset (dropping out the Prewarn, if passed). If SP is selected (D is pressed), the unit starts at the Preset and counts “down” towards zero (dropping out the Prewarn at its set value.)

B or **D**

Selects by moving the cursor under the arrow by **RO** or **SP**



Store R0 or SP.

DEC LOC

DEC LOC allows the user to choose where the decimal point will be located when the Batch Count or Grand Total are displayed. The decimal point is for display only and does not affect K Factors. (The K Factor must be scaled to reflect the DEC LOC, see Section 7 for calculating the K Factors) Simply press the keypad numbers to move the decimal point. Only one decimal point can be displayed, multiple decimal points are not available. Pressing 0 turns off the decimal point.

4

DEC LOC

As an example, the decimal point will move to the right of the fourth digit from the right (displays units and thousandths).



Store new DEC LOC.

Run Mode.

The Counter portion of the Batcher is now set up.

3-10 Setup Procedure For The Batcher (continued)

MENU ITEM 5 RATE

Setting the Ratemeter

<u>PRESS</u>	<u>DISPLAY</u>
D	PRESET ↓
D	PREWARN ↓
D	PRE TYP ↓
D	COUNT ↓
D	RATE ↓
ENT	K FACTOR

This selects the Ratemeter portion of the menu.

K FACTOR flashes then shows the current Ratemeter K Factor.

Note: The K Factor setup is skipped if the unit has 16 Point option. The unit goes directly to WINDOW.

CLR	0 Flashes.
Clears out existing K FACTOR.	

1 2 D 0 5 6	12.056 Flashes.
Sample K Factor, or enter calculated value from notes or worksheet.	

ENT	WINDOW ##
Store new K Factor.	
<u>Normally the ratemeter updates each second.</u> If no signal comes in during that time, the ratemeter will wait until the window times out or a signal comes in; the display will not update. The window is the maximum sample time, in seconds, on which the waiting period is based. The range is from 02 to 24 seconds.	

CLR	WINDOW 00
Clears out existing WINDOW number value.	

5	WINDOW 05
As an example, extends the window to 5 seconds.	

continued on next page

3-10 Setup Procedure For The Batcher (continued)

MENU ITEM 6 **RATE** (continued from previous page)

From the previous page, we are in the SIG FIG setting portion of the Ratemeter setup Menu.

PRESS

DISPLAY

ENT

SIG FIG ##

Store new WINDOW.

SIG FIG indicates how many meaningful digits are shown. For example, if SIG FIG is set at three; a rate of 24737.89 will be displayed as 24700; a rate of 0.739216 will be displayed as 0.739. Note that trailing zeroes will be inserted only if necessary. Digits beyond the SIG FIG value are truncated and zeroes are inserted as needed, no rounding is done.

CLR

SIG FIG 00

Clears out existing SIG FIG number value.

4

SIG FIG 04

As an example,

display will show 4 significant figures.

ENT

WEIGHT##

Store new SIG FIG.

WEIGHT is an averaging factor. Higher settings provide more averaging for a more stable rate display. Derived from:

$$\frac{(\text{OLD DATA} \cdot \text{"WEIGHT"} + \text{NEW DATA})}{(\text{"WEIGHT"} + 1)}$$

CLR

WEIGHT 00

Clears out existing WEIGHT value.

4

WEIGHT04

As an example,

ENT

RUN MODE

The Ratemeter portion of the Batcher is now setup.

3-10 Setup Procedure For The Batcher (continued)

MENU ITEM 6 LOCKOUT

This menu item uses a 4 digit security code to prevent unwanted changes in the programming or improper use of the Batcher. The unit is shipped from the factory with a security setting of 00 and a lockout code of 1000.

Security example: First set the security shut down time in the Lockout menu then go to the Run Mode. Press the START button. The word STARTED should briefly appear. If no signal comes in before the security time is reached, the unit locks and displays SECURITY. Once the unit locks all buttons except 0 thru 9 are disabled. To unlock the unit simply press in the lockout code. When the unit is unlocked all menu features are available for change.

Lockout example: To lock the unit, first make sure it is in the Run Mode, then press 1 - 0 - 0 - 0. The words LOCK ON should briefly appear. Once the unit is locked:

- a. Preset can still be accessed and changed.
- b. Prewarn can still be accessed but cannot be changed.
- c. the rest of the menu cannot be accessed.

To unlock the unit simply press 1 - 0 - 0 - 0. The words LOCK OFF will appear briefly. When the unit is unlocked all menu features are available for change.

To put in a different security time or lockout code follow this setup procedure.

<u>PRESS</u>	<u>DISPLAY</u>
D	PRESET ↓
D	PREWARN ↓
D	DEV TYP ↓
D	LOCKOUT ↓
ENT	SECUR ##

SECUR is the time, in seconds, that the unit will wait between pulses or for a signal to come in once STARTED. For example: The SECUR is set at 15, in run mode the START button is pressed. If at any time the unit does not receive a signal for 15 seconds the display will go to security and the unit will lock itself. The unit retains elapsed security time if STOPPED before security times out. When restarted, the unit resumes security timing from where it left off. As soon as a signal comes in the security time is reset. Entering a security time of 00 disables the security feature.

CLR	SECUR 00
Clears out existing security time.	
3 4	SECUR 34
As an example, unit waits 34 seconds before Security Mode.	

Continued on next page

3-10 Setup Procedure For The Batcher (continued)

From the previous page, we are in the **CODE** setting portion of the Lockout setup Menu.

PRESS

DISPLAY

ENT

CODE

Store new security time.

Enters device routine to program in a 4 digit Lockout Code. The word CODE appears briefly then the current Lockout Code number is displayed.

CLR

0 Flashes.

Clears out existing Lockout Code.

1 2 3 4

1234 Flashes.

Sample Lockout Code, or enter desired value from notes or worksheet.

Be sure to record any changes in the lockout code in case it is forgotten!

ENT

Last count, unit now in Run Mode.

Store new LOCKOUT Code. (Sample tryout below.)

1 2 3 4

LOCK ON

Enter the sample / new value . . . the unit is now locked!

1 2 3 4

LOCK OFF

Enter the sample / new value. . . the unit is now unlocked!

The lockout procedure is finished.

3-10 Setup Procedure For The Batcher (continued)

MENU ITEM 7 OUTCARD

If the unit is equipped with a serial communications card, the setup parameters in the following menu will make the Batcher compatible with the master terminal. The Unit Identification Number (if multiple units are used), Baud Rate (speed at which the signal is transmitted) and Parity are selectable. A 7 bit, ASCII character, with one start bit, one stop bit and the parity makes up the standard ten bit transmission character. For more details see Section 8.

<u>PRESS</u>	<u>DISPLAY</u>
D	PRESET ↓
D	PREWARN ↓
D	DEV TYP ↓
D	LOCKOUT ↓
D	OUTCARD ↓

ENT UNIT ##
The Unit ID Number identifies the unit for multi-drop communications. Up to 15 units may be on one line. A unit will stay off line until its Unit ID number is received. It will then stay on line until a carriage return is sent. At which time, it will send any requested information and take itself off line. The range of the unit ID number is 00 to 15

NOTE:
 A Unit ID number of 00 will keep the unit on line at all times. No Unit Number prompt is needed and carriage returns will not take the unit off line.

Regardless of the above, all requests for information are replied to at the units earliest convenience.

CLR Clears out existing Unit ID number.	UNIT 00
1 2 Sample Unit ID number.	UNIT 12
ENT Enters new Unit ID number.	PL ↓ SER ↓
D Chooses SER (PL not available)	
ENT BAUDRATE flashes then shows current Baud rate.	BAUDRATE

Continued on next page.

3-10 Setup Procedure For The Batcher (continued)

From the previous page, we are in the **BAUDRATE** setting portion of the Outcard setup Menu.

PRESS

DISPLAY

By pressing the **D** button repeatedly, the available Baud rates will be displayed. The menu will cycle through the rates again whenever the bottom of the list is reached. Simply stop on the Baud rate desired and hit the **ENT** button. **The Baudrate is the speed at which the unit communicates.**

D	300 ↓
D	600 ↓
D	1200 ↓
D	2400 ↓
D	4800 ↓
D	9600 ↓
Press D to go to 300 ↓	

ENT

PARITY

Press **ENT** at desired Baud rate. **PARITY** flashes then last Parity selected is displayed.

By pressing the **D** button, the available Parity selections will be displayed. The menu will cycle through the rates again whenever the bottom of the list is reached. Simply stop on the Parity desired and hit the **ENT** button.

Parity is a way for the terminal to determine if the signal it received has reached it intact. It does this by counting the number of bits received and checking it against the parity bit. The parity bit is turned on if it corresponds to the number of bits in the character. For example: If the bits add up to an odd number and the parity selected is even then the parity bit will not be turned on. (If the parity was odd then it would be turned on.) Mark or Space turn on (or off respectively) the parity bit with each character sent, all of the time.

Note: The Batcher will always ignore the parity bit for all characters it receives. The parity selection is provided for the master terminal only.

D	EVEN ↓
D	ODD ↓
D	MARK ↓ (Parity Bit always on)
D	SPACE ↓ (Parity bit always off)
Press D to go to EVEN ↓	

ENT

Last count, unit now in Run Mode.

Press **ENT** at desired Parity, Parity stored.

The Serial Communications Port is now set up.

3-10 Setup Procedure For The Batcher (continued)

MENU ITEM 8 ALG OUT

This section is for models of the batcher with the analog output feature. **The Analog Output card is a (0 - 20) or (4 - 20) mA current sink.** The low (0mA) or (4 mA) and high (20mA) settings may be set at any range. Attempting to set the high setting lower than or the same as the low setting will display the warning message HIGH ≤ LOW and send the unit back to the low setting section of the routine. The unit will not exit the ALG OUT routine until a proper setting has been entered. If the displayed rate is below the 4 mA setting, the current driver will stay at 4 mA. This allows for offsetting the low end of the output signal. If the displayed rate exceeds the 20 mA setting the current driver will stay at 20 mA.

Note: The current sink follows (tracks) the display.

The Analog Output option is not available on Square Law Analog Input units.

<u>PRESS</u>	<u>DISPLAY</u>
D	PRESET ↓
D	PREWARN ↓
D	DEV TYP ↓
D	LOCKOUT ↓
D	OUTCARD ↓
D	ALG OUT ↓
ENT	ANLG RT ↓

The analog output may correspond to the ratemeter or the totalizer. At this point, the selection is made by pressing ENT on the appropriate prompt. ANLG RT is the prompt for the rate meter. ANLG CT is the prompt for the batch totalizer.

D	ANLG CT ↓
Press D to toggle between selections.	
ENT	SET LOW
Enters the routine for setting up the Analog Output card. SET LOW flashes then shows the 4 mA Setpoint value.	
CLR	0 Flashes.
Clears out existing Low Setpoint value.	
1 7 5 D 5	175.5 Flashes.
Sample Low Setpoint, or enter value from notes or worksheet. (D for decimal point.)	
ENT	SET HIGH
Low Setpoint is stored. SET HIGH flashes then shows the 20 mA Setpoint value.	

Continued on next page.

3-10 Setup Procedure For The Batcher (continued)

From the previous page, we are in the **SET HIGH** setting portion of the ALG OUT setup Menu.

PRESS

DISPLAY

CLR

0 Flashes.

Clears out existing High Setpoint value.

6 7 5 9 D 5

6759.5 Flashes.

Sample High Setpoint, or enter value from notes or worksheet. (D for decimal point.)
If High Setpoint is too low, the warning HIGH≤LOW will be displayed and the unit will return to the SET LOW routine.

ENT

Last count, unit now in Run Mode.

High Setpoint is stored.

Analog Output is set.

MENU ITEM 9 OUT FREQ

All models of the Batcher have a pulse generator built in to them. **This Output Frequency generator sends pulses out which are scaled relative to the input signal via the counter K Factor.** This means that for every time the counter increments a pulse is available at the output. Various output frequencies are available to the user for driving external devices. In case the rate exceeds the output frequency selected, a 9999 pulse buffer is provided to hold the excess pulses. If the buffer is completely filled the warning message DATALOST will flash on the display.

PRESS

DISPLAY

D

PRESET ↓

D

PREWARN ↓

D Press until . . .

OUT FREQ ↓

ENT

20000 ↓

Enters the routine for setting up the Frequency Output.
The display shows the last Frequency selection.

D

2000 ↓

D

200 ↓

D

10 ↓

Press D to go to 20000 ↓
Press ENT at desired Frequency.

ENT

Last count unit now in Run Mode.

Pulse Output is now set.

3-10 Setup Procedure For The Batcher (continued)

MENU ITEM 10 16 POINT

This section is for models of the Batcher which have 16 Point Linearization. **This option allows the user to key in from 3 to 16 different frequency points (inputs per second) and assign different K Factors dividers from 0.00011 to 999999 for each of these frequencies.**

Please refer to the K Factor worksheets (Section 7) or other notes you may have prepared.

<u>PRESS</u>	<u>DISPLAY</u>
D	PRESET ↓
D	PREWARN ↓
D Press until . . .	16 POINT ↓
ENT	SECONDS ↓
D	MINUTES ↓
D	HOURS ↓

The unit calculates the base rate per second from the incoming frequency and the specified K Factor. The rate can then be displayed in 3 ways:

SECONDS: The base rate.

MINUTES: The base rate times 60.

HOURS: The base rate times 3600.

D	TEST ↓
----------	--------

TEST is used to help set up the points and K Factors. In this mode the K Factor is automatically set to (1) one for both rate and total for all 16 points. Further information on this mode can be found in Section 7-3 of this manual.

ENT	POINT 00
------------	----------

Press ENT on desired rate display. The unit now enters the Frequency and K Factor setup mode.

To escape from this mode, press ENT when POINT 00 is being displayed.

Enter any other point from 1 to 16 via the front keypad and press ENT to continue.

Note: If the point number entered is greater than 16, the unit will default back to point 16.

Continued on next page.

3-10 Setup Procedure For The Batcher (continued)

From the previous page, we are in the **POINT** setting portion of the 16 Point setup Menu.

<u>PRESS</u>	<u>DISPLAY</u>
1 then ENT	POINT 01
ENT	F 1
The unit displays the last frequency entered for Point 01.	
CLR	F 0
Clears out existing frequency for Point 01.	
1 0 0	F 100
Sample frequency, or enter desired value from worksheets.	
ENT	K 1
The unit displays the last K Factor entered for Point 01.	
CLR	K 0
Clears out existing K Factor for Point 01.	
1 0	K 10
Sample K Factor, or enter desired value from worksheets.	
ENT	POINT 02
The above procedure is now repeated for Point 02. The setup continues in this manner until up to 16 points are entered.	
<p>Note: A minimum of (3) three points must be entered. <u>All frequencies of consecutive point numbers must be entered in ascending order, beginning with 0 for the first point.</u></p> <p>Please read Section 7-3 for all rules concerning 16 Point Frequency and K Factor entry.</p>	
<u>PRESS</u>	<u>DISPLAY</u>
CLR	POINT 00
Clears Point number in preparation for exit of 16 Point setup routine.	
ENT	Last count, unit now in Run Mode.
Press ENT on Point 00 to exit 16 Point routine.	

Note: Unit will flash **BAD FREQ** if there is a sequence error. The unit will then display the sequence error point number so that corrections can be made.

16 Point linearization is now setup.

3-11 Run Mode

3-11.1 The Display

In the Run Mode the display will initially display:

- a) Zero, if setup to reset to zero.
- b) Preset number, if set to reset to preset .
- c) A warning message (See Section 6-1)

The unit will accept input signals and display Rate, Batch Total or Grand total.

The Batch Total is displayed as a number.

The Rate is displayed as “R” followed by a number.

The Grand Total is displayed as a flashing number.

(The Grand Total flashes so that it will not be confused with the Batch Total.)

To toggle between the Rate and Batch Total, press the C button. Press the ENT button at any time to view the Grand Total, then press it again to go back to the Rate or Batch Total.

3-11.2 Resetting (Clearing) the Totalizers.

To clear the Batch Totalizer,

- a) the unit must be in the Run Mode.
- b) the unit must be displaying the Batch Total.
- c) the unit must not be locked out.*

If the above conditions are met, press the CLR (clear) button. The display should then show the preset or zero depending on how the unit is configured.

To clear the Grand Totalizer,

- a) the unit must be in the Run Mode.
- b) the unit must be displaying the Grand Total.
- c) the unit must not be locked out.

If the above conditions are met, press the CLR button. The display should then show zero.

* The unit may be reset if it is locked out by putting a 3-30 VDC signal to pin 5 on the rear of the unit.

3-11.3 Locking the Unit

The unit is shipped from the factory unlocked. To lock the unit, it must be in the Run Mode. The unit is shipped from the factory with a Lockout Code of 1000.

As a test, when you receive the unit, power it up and press 1 then 0 three times. The display should briefly show LOCK ON. This means that the unit is now “locked out”. Press 1 then 0 three times again. The display should then show LOCK OFF briefly. This means that the unit is now unlocked.

What LOCK ON or “Locked Out” means:

- a) the Grand Totalizer cannot be reset.
- b) only the preset can be accessed and changed.
- c) the prewarn can be accessed but **not** changed.
- d) the rest of the Menu cannot be accessed.

The unit will still:

- e) accept input signals
- f) display Rate, Batch Total and Grand total.
- g) have Start, Stop and Rate/Total buttons enabled.

LOCK OFF means that the unit functions normally as described in this manual.

The Lockout code can be changed or viewed by accessing Lockout in the setup Menu. (See Section 3-3; Menu Item 4; Lockout.) The unit must Unlocked to do this so be sure to record any Lockout code changes in case it is forgotten.

The Lock toggles back and forth from LOCK ON to LOCK OFF each time the code sequence is entered. The last four digits pressed, while in the Run mode, are the ones that the unit checks for Lockout code sequence. For example: while 1000 will unlock/lock a new unit from the factory, so will the number 347191000 (the last four digits are the code sequence, so, this number works also!).

RECORD ALL LOCKOUT CODE CHANGES.

3-11 Run Mode (continued)

3-11.4 Start and Stop Operation.

The Batcher is designed for batching operations. The batching operation is controlled by two internal relays, Preset and Prewarn settings and the CLR, START and STOP buttons on the front panel.

A typical operation proceeds as follows:

- a) The Preset is accessed and changed to the amount desired.
- b) The unit accepts input signals
- c) The CLR button is pushed to reset the Batch Totalizer.
- d) The Start button is pushed and the process begins.
- e) The Stop button can be pushed at any time to temporarily halt the process (the Start button resumes it from where it stopped).
- f) The display shows Rate, Total or Grand Total.
- g) The Prewarn is reached and the process is slowed down.
- h) The Preset is reached and the process is halted.

The Batcher will always accept input pulses whether the unit is Started or not! All pulses on the input terminal are counted and shown on the display. This means that all pre-run and post-run pulses will be recorded. For this reason, always press the CLR button before start.

The START button energizes the Preset and Prewarn relays.

The STOP button de-energizes the Preset and Prewarn relays.

(The CLR button is discussed in section 3-11.2.)

3-11.4 Start and Stop Operation (continued).

The START button initiates the batch sequence. Once the unit is started:

- a) The display will prompt the operator with the word STARTED.
- b) Both relays will engage (Unless the Prewarn has been reached already).
- c) All buttons on the front panel will be locked out except the STOP button and ENT button which allows access to the Grand Totalizer.

NOTE: Once both Prewarn and Preset points are reached, the unit cannot be started until it receives a reset signal or the CLR button is pressed.

The STOP button is used to stop a batch that has already started. When the STOP button is pressed:

- a) The display will prompt the operator with the word STOPPED.
- b) The Preset and Prewarn relays will de-energize.
- c) The unit will still accept input pulses.
- d) All buttons on the front panel will be usable.
- e) The unit may be restarted by pressing the START button.

3-12 Internal Operation

3-11.1 Digital Inputs and Computations

The 3-30 Volt input signal is filtered electronically (See Section 4-1, Digital Pulse Inputs).

Computations:

$$\frac{\text{Pulses In}}{\text{Count K Factor}} = \text{Count}$$

$$\frac{\text{Pulses In}}{\text{Rate K Factor}} = \text{Rate}$$

$$\text{Batch Total} = \sum \text{Count (since last Batch Reset)}$$

$$\text{Grand Total} = \sum \text{Count (since last Grand Total Reset)}$$

$$\text{Rate} = \frac{\text{Rate}}{\text{Tau}}$$

Tau = 1 sec or WINDOW if (Rate / 1 sec) = 0
(See Sections 1-3 and 3-10, Setting the Ratemeter)

Frequency Out = Count
(Sequenced out as per OUT FREQ selection and buffered to 9999 pulses)
(See Sections 1-3 and 3-10, OUT FREQ)

$$\text{Analog Out} = \frac{(\text{Rate} - \text{SET LOW})}{4} \times 16 + (\text{SET HIGH} - \text{SET LOW})$$

(See Sections 1-3 and 3-10, ALG OUT)

Prewarn Out =
Count ≥ Preset - Prewarn (if Reset to 0)
Count ≤ Prewarn (if Reset to Preset)

Preset Out =
Count ≥ Preset (if Reset to Zero)
Count ≤ 0 (if Reset to Preset)

3-12.2 Analog Inputs and Computations

The Analog input signal is filtered electronically and converted to a 0 - 10000 Hz input frequency. (See Section 7, K Factor Calculation and Section 4-2, Analog Inputs).

Computations:

$$\frac{\text{Pulses In}}{\text{Count K Factor}} = \text{Count}$$

$$\frac{\text{Pulses In}}{\text{Rate K Factor}} = \text{Rate}$$

$$\text{Batch Total} = \sum \text{Count (since last Batch Reset)}$$

$$\text{Grand Total} = \sum \text{Count (since last Grand Total Reset)}$$

$$\text{Rate} = \frac{\text{Rate}}{\text{Tau}}$$

Tau = 1 sec or WINDOW if (Rate/1 sec) = 0
(See Sections 1-3 and 3-10, Setting the Ratemeter)

Frequency Out = Count
(Sequenced out as per OUT FREQ selection and buffered to 9999 pulses)
(See Sections 1-3 and 3-10, OUT FREQ)

Prewarn Out =
Count ≥ Preset - Prewarn (if Reset to 0)
Count ≤ Prewarn (if Reset to Preset)

Preset Out =
Count ≥ Preset (if Reset to Zero)
Count ≤ 0 (if Reset to Preset)

SECTION 4 INPUTS

4-1 Digital Pulse Inputs (Terminal 4)

Digital Pulse Inputs: The input board is a separate board that is plugged into the mother board just behind the display. All digital inputs are on the same board. There are four dip switches on the board. The input conditioning characteristics may be altered by changing the dip switches. A valid pulse is one which makes a transition from the off state (low) to the on state (high): a positive going edge. The off state is 0 - 1 VDC with respect to Terminal 12 (Ground). The on state is 3 - 30 VDC with respect to Terminal 12. The input impedance is 10 K ohms. At 30 VDC, the current draw will be 3 mA. This should be the maximum current that the Batcher will draw. Acceptable pulse width is determined by the dip switch settings (See Table 4-1 below).

DIP SWITCH SETTINGS

SW1	SW2	SW3	SW4	Conditioning
ON	ON	---	---	0-40 Hz min. 12.5 msec on/off
ON	OFF	---	---	0-400 Hz min. 1.25 msec on/off
OFF	OFF	---	---	0-20000 Hz min. 0.25 usec on/off
---	---	OFF	OFF	needs sourcing input (drive input high)
---	---	OFF	ON	needs sinking input (pull input low)

Table 4-1

4-1 Digital Pulse Inputs (continued)

4-1.1 STANDARD: High Impedance (Terminal 4).

Has a 10 K Ohm pull down resistor to ground (Terminal 12) and must be driven high. Typical drivers include a contact closure from a 3-30 VDC source (such as Terminal 13), a PNP transistor (proximity switch or other device) or an amplified signal from an inductive pickup. Remember, the input signal must be referenced to Terminal 12 of the Batcher. (See Section 2-5, Fig. 2-2 Typical Digital Wiring Connections)

4-1.2 High Impedance with pull-up (Terminal 4).

Has a 4.7 K Ohm pull up resistor to +5 VDC and must be pulled low. Typical drivers include a contact closure to Ground (such as Terminal 12), or an NPN transistor (proximity switch or other device). Remember, the input signal must be referenced to Terminal 12 of the Batcher. (See Section 2-5, Fig. 2-2 Typical Digital Wiring Connections)

Idea: This input works well with TTL devices.

4-1.3 Reset Input (Terminal 5)

Identical to the Standard, High Impedance Input with one exception. The input speed is fixed for a minimum pulse width of 5 msec.

Note: The reset input will not be changed to a sourcing type of input even if the dip switch is set for pull up or is changed to the pull up settings.

4-2 Analog Inputs 5A - 5E, 6A (Terminal 4)

The input signal modules are mounted, just like the Digital board, behind the display. Analog inputs all use the same board, likewise so do the Analog-In/Out inputs. These boards are not field modifiable (unlike the Digital board). Each board is calibrated at the factory for its particular input type.

4-2 Analog Inputs (continued)

- 4-2.1 **5A:** 4-20 mA; 250 Ω input impedance.
5B: 0-20 mA; 250 Ω input impedance.
5C: 1-5 VDC; 15 KΩ input impedance.
5D: 0-5 VDC; 15 KΩ input impedance.
5E: 0-10 VDC; 15 KΩ input impedance.

The above inputs take the analog signal and scale it from 0 to 10000 pulses per second by using a highly linear voltage to frequency converter. These pulses go to the processor to be scaled by the K Factors. To determine the K Factor, see Section 7, Calculating the K Factor.

- 4-2.2 **6A:** Square Law: 4-20 mA; 250 Ω input impedance.

The Square Law input is a special input that compensates for non-linear input types. Specifically, inputs that require square root extraction to provide accurate count and rate determinations. The input signal is converted to a 0 to 10000 pulse per second input to the processor (See Table 4-2 below).

mA Input	Freq.	mA Input	Freq.
4	0000	10	6123
5	2500	12	7071
6	3535	16	8660
7	4330	18	9354
8	5000	20	10000

Table 4-2

To calculate the freq. for a particular input use the following formula.

$$\sqrt{\frac{\text{mA} - 4}{16}} \times 10000 = \text{Freq. to processor}$$

For example: to calculate the frequency for 9 mA Input.

$$\sqrt{\frac{9 - 4}{16}} \times 10000 = 5590 \text{ Freq. to processor.}$$

4-2.3 Analog Inputs Exchange

If an analog sensor cannot be obtained that matches the Batchter input, it is recommended that the Batchter be returned to have the analog input module exchanged and recalibrated. Recalibration should only be attempted by someone who has the training to open the unit and work with grounded equipment necessary to protect the static sensitive CMOS circuitry. For instructions on how to return the unit for exchange see Section 2-2.

4-2.4 Analog Inputs Calibration

(All units have been calibrated at the factory)

Warning: This unit contains static sensitive components. Observe proper precautions!

- Set the ratemeter at 6 SIG FIG; the window at 01; and the K Factor at 1.00.
- Remove the case and locate the analog input card mounted behind the display (see Section 6-3).
- Locate the two 0.3 inch square pots R3 and R15. These numbers should be silkscreened underneath them on the board.
- Input a very accurate low signal and adjust R3 (left side from the front) so that the display reads .0001 to 0000.
- Input a very accurate high signal and adjust R15 (right side from the front) so that the display reads 9999 to 10000.
- Repeat steps d and e until the unit is reading as close as possible to 0000 on the low side and 10000 on the high side. This should only take a few tries.
- Re-case the unit and setup the Menu as desired.

If problems occur during calibration please contact the factory for exchange or to arrange for factory calibration.

4-3 DC Power Inputs (Terminals 12, 14)

The Batcher may be powered by an external DC power supply. The supply must provide 12 - 27 Volts DC and at least 280 mA of current. The positive side (+DC) of the DC supply should be hooked to Terminal 14 and the negative (or Ground) side to Terminal 12.

NOTE: Units powered by DC Voltages do not have an isolated voltage out on Terminals 15 and 16 or +12 VDC on Terminal 13.

4-4 AC Power Inputs (Terminals 17, 18)

The Batcher may be ordered for 110 or 220 VAC power. The unit requires single phase 50/60 Hz AC power.

The voltage range is $\pm 15\%$ of the rated voltage. Voltages below this range will not power the unit. Voltages above this range may damage the unit. The Batcher is relatively immune from electrical noise on the AC lines. However, in extremely noisy applications some line conditioning or filtering may be necessary. If fusing is required, external fusing must be supplied.

Note: The Batcher has no internal fuse to blow out. If the unit does not function when power is applied, contact the factory for assistance or to arrange for repair.



Caution: An external fuse is required:
DC Power: 0.5 Amp
AC Power: 0.125 Amp

SECTION 5 OUTPUTS

The Batcher has five different possible types of outputs for controlling external devices or monitoring the rate and totals. They are: Frequency Output, Relay Outputs, Open Collector Outputs, and Optionally available Analog Output (not available on models with (Square Law input), and RS232, RS422, or RS422M Serial Communications.

5-1 Frequency Output (Terminal 2)

5-1.1 Electrical Characteristics of Frequency Output

The Batcher generates a pulse out for each factored count. A sinking NPN transistor output (see Figure 5-0.1), can drive external devices at various rates selected through the keypad menu see Table 5-0.2 below). The Open Collector sinks 30 VDC maximum to 1 volt maximum with a maximum current of 100 mA.

Speed (Hz)	10	200	2000	20000
Min. on/off (msec)	47.5	2.0	0.2	0.013

Table 5-0.2

Applications: Remote totalizers, ratemeters or other monitoring devices.

10 Hz: Electromechanical totalizers
Programmable Controller inputs

200 Hz: Electronic totalizers
Programmable controllers with high speed input cards.

2000 Hz: High speed totalizers.

20000 Hz: High speed totalizers.

5-1.2 Internal Buffer for Frequency Output

An internal buffer will store up to 9,999 counts if the scaled input generates pulses faster than the output speed selected. The warning message "DATA LOST" flashes on the screen when the buffer overflows (see Section 6-1, Warning Messages). This indicates that the counts being totalled and the scaled outputs may be incorrect.

Note: All counts stored in the internal buffer will be pulsed out at the selected frequency even if the counter is reset before it is finished sending them.

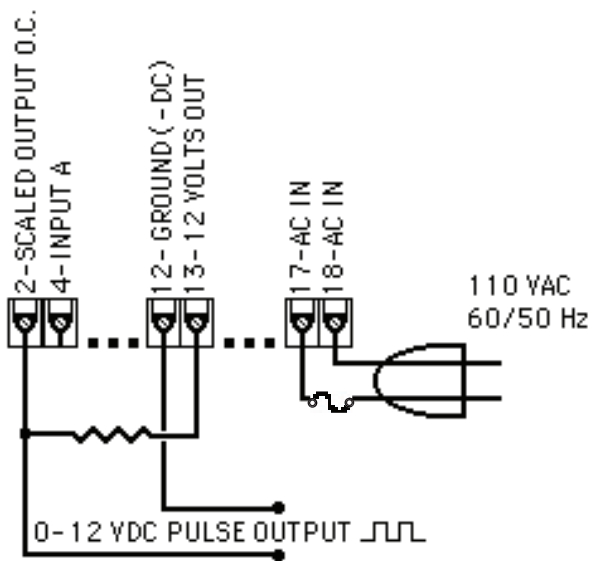

Figure 5-0.1

5-2 Control Outputs

5-2.1 SPDT Relay Version (Standard)

When the start button is pushed, the two relays engage simultaneously to start flow. When the prewarn number is reached, one relay drops out. When the preset number is reached, the other relay drops out. The user may enter the two numbers when setting up the batch counter (see Section 3-3, Menu Items 1 and 2). The contacts are rated at 10 A, 120/240 VAC or 28 VDC.

5-2.2 Open Collector Version (Terminal 19, 20).

The NPN, Open Collector Transistors, sink a maximum of 250 mA at 30 VDC when active. They behave in the same manner as the Relay Outputs (see Section 5-2.1 above). The Open Collector outputs are available on units with relay outputs, but, please observe the following precautions.

Note: When relays are used, 10 VDC is provided at the transistor outputs through the relay coils. If current greater than 2 mA is drawn, the relay will remain energized. **Applying greater than 10 VDC to the Open Collector outputs may destroy the unit. The transistor will sink 100 mA in the "ON" state with relays installed.**

5-3 Optional Analog Output (Terminal 3)

5-3.1 Electrical Characteristics of Analog Output

The Analog Output option is not available on units with Square Law inputs. Controlled by an Open Collector transistor, it gives a linear 4 to 20 (or 0 to 20) mA sink which corresponds to displayed rate or total readings. A sinking driver pulls a current to ground, across the user's external device (such as a strip chart recorder, computer, external meter, etc). In the Setup mode the user is prompted to set the output to correspond to rate or total and set the low and high (4/0 to 20mA) parameters to which the analog signal will correspond.

Idea: The Batcher can supply the 24VDC to power the current loop. (Connect pin 15 to 13, Pin 16 is now +24 VDC with respect to pin 12.) Connect Pin 16 to the + DC side of the external device and connect Pin 3 to -DC side of the external device (see Figure 5-2.1).

5-3 Optional Analog Output (continued)

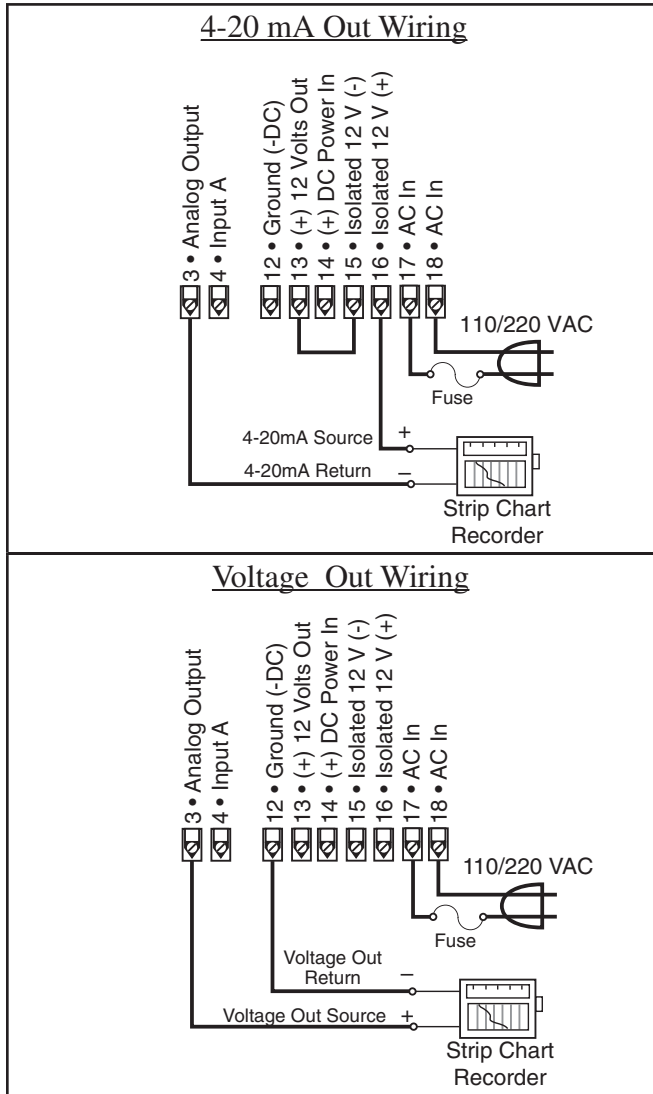

Figure 5-2.1

5-4 Optional RS232 / RS422 Serial Communications

This option allows the Batcher to act as a slave to a master terminal. It may be accessed for counts, rate, presets and K Factors. Up to 15 units can be linked together in parallel and addressed separately to transmit unit status or accept new set points using the standard ASCII format. Baud rates of 300, 600, 1200, 2400, 4800 or 9600 as well as choice of odd, even, space, or mark parity can be selected by keypad control. Further information and more details are provided in Section 8 at the end of this manual.

SECTION 6 TROUBLE SHOOTING AND MAINTENANCE GUIDE

6-1 Warning Messages

6-1.1 PREWRONG

Indicates that the values in Preset and Prewarn are not acceptable. This condition will occur when the Preset value is less than the Prewarn value. The display will continue to display this message until the error is corrected. To change the Preset and Prewarn values see Section 3-3, Setup Procedure.

6-1.2 DATALOST

Warning message that indicates the unit is receiving pulses faster than 20000 pulses per second or the data buffer is full. In either case the display will not show the proper count or rate and the frequency output will be inaccurate. There are three possible remedies:

- Check to see that your input is not exceeding the Batcher ratings of 20 KHz Max. Input speed.
- Change your OUT FREQ settings to handle a higher count speed (Section 3-3, Menu Item 7).
- Change your count K Factor to a larger number, since the output frequency is based on the factored count (Section 3-3, Menu Item 3).

6-1.3 RFFFFFFFF

Indicates that the factored input rate has exceeded a 7 digit number. The ratemeter cannot handle numbers larger than 7 digits (i.e. 9999999). Change the Rate K Factor to a larger number (Section 3-3, Menu Item 3) to correct this problem.

6-1.4 LOCK ON

Indicates that the unit has been locked out! The unit must be unlocked before any changes can be made. See Section 3-3, Menu Item 4 to unlock the unit.

6-1 Warning Messages (continued)

6-1.5 BAD FREQ

Indicates that the values in the 16 Point setup are not acceptable. This condition will occur when the frequency values are not in ascending order. The display will continue to display this message until the error is corrected. To correct the error see Section 3-3, Setup Procedure.

6-1.6 SECURITY

Indicates that no signal has come in for the duration time set in the Lockout menu. Lockout code must be entered before the unit will continue. Section 3-3, Setup Procedure.

6-2 Troubleshooting

6-2.1 General

The following troubleshooting procedures have been developed as an aid in locating defects. Not every possible problem has been listed, but a general isolation procedure for tracking down problems has been given. A standard recommendation is the removal of power for 2 seconds. This allows the microprocessor to go through a reinitialization cycle at power up. If it is determined that the unit is faulty, contact your local Factory Representative or Sales Office concerning replacement. The Batcher is not field serviceable and all repairs should be performed by the factory.

6-2.2 Problems

Symptom: **Display will not light.**

Possible Cause: No power to unit, power to unit not to specifications or bad connection between display board and mother board.

Test Procedure: See Specifications Section 1-4 for proper input voltages. Then;

- a) Check AC voltage input on terminals 17 & 18.
- b) (if DC Powered unit) Check DC voltage input on terminals 12 & 14.
- c) Check connection of display board to mother board

Corrective Action: If all checks okay, replace unit.

6-2.2 Problems

Symptom: **Unable to start batch.**

Possible Cause #1: Displayed Batch count already exceeds the Preset value.

Test Procedure: Check Preset value against the displayed value. If the Preset is less, go to corrective action.

Corrective Action: Reset the unit by pressing the CLR button or change the Preset to a larger value.

Possible Cause #2: Incorrect programming.

Test Procedure: Check for programming errors, review manual.

Corrective Action: Reprogram unit as required.

Possible Cause #3: Defective Circuit board or component.

Test Procedure: Press the Start button and check for relay action. An OHM meter across the appropriate relay terminals should give the proper indication. (Be sure to disconnect all power to the relay terminals first!)

Corrective Action: If no relay action replace unit.

Symptom: **Unit not totalizing.**

Possible Cause #1: Incorrect programming.

Test Procedure: Check for programming errors, review manual. For Example, if the K Factor is too large it may take some time before a count is registered on the display.

Corrective Action: Reprogram unit as required.

Possible Cause #2: Input signal invalid.

Test Procedure: See Specifications Section 1-4 for proper input signals. Then use oscilloscope to;

- a) Check Analog input on terminals 3 and 12 for proper current or voltage levels.
- b) (if Digital unit) Check Digital voltage input on terminals 3 and 12.

Corrective Action: If inputs check okay, replace unit.

6-3 Removing the Case

To install or change the input or data interface cards, the case must be removed. **Remove all power before opening the case.** CMOS logic is used so observe standard precautions against damage by static discharge. On units RS232 or RS422, two screws on the back, holding the top left connector, have to be removed. Next, remove the six (6) flat head screws behind the front bezel and lift off the bezel assembly. Slide the main board display out the front of the case by pushing from the rear. Once modifications are made, reverse the procedure to reassemble the unit. Make sure that the main board is in the track. The six (6) screws that hold the panel must be tight to seal the rubber keypad panel assembly, approximately 0.6 in-lb torque.

6-3.1 Input Card Modification

Follow the instructions for removing the case in Section 6-3. The Input card is mounted just behind the display and plugs onto the 15 pin post connector. Remove the board and make desired changes. When installing the Input card, make sure that the component side of the board is facing the front and that the 15 pin connector is mated properly and not offset to the side. Replace the front panel per Section 6-3.

6-3.2 Serial Communications Interface Installation

Follow the instructions for removing the case in Section 6-3. The RS232, RS422 and RS422M cards have a 15 contact ribbon cable that plugs into the female connector next to the heat sink. Choose the proper Interface card. With components on top and subminiature connector to the back plug in the harness and mount the card on the four (4) standoffs provided. After the main board is inserted into the case replace the front panel as per Section 6-3.

6-4 Maintenance

The Batcher does not require any "Routine Maintenance" by the user. If a problem should occur, and all troubleshooting procedures have been exhausted, contact your local representative or distributor (phone number on cover of manual).

SECTION 7 CALCULATING THE K FACTORS

7-1 General

The key to accurate flow measurement with the Batcher is correct scaling. The electronics of the unit have been designed for stability and repeatability. Even the finest measuring device and equipment cannot make up for improper factoring and programming. Due to the complexity of the concept of K Factors, this special section has been provided for those who still find it hard to understand. A separate worksheet has also been provided with this manual to help in calculating the K Factors. It is hoped, that between this section of the manual and the worksheet, that any questions you may have, regarding the K Factor, will be answered.

7-1.1 What is a K Factor?

The K Factor is a divider. This means that if the K Factor is greater than 1, it will diminish any input signal. Conversely, if it is less than 1, it will increase any input signal. The K Factor range of the Batcher is from 0.0001001 to 99999999. This allows a wide range of factoring from greatly increasing (to display a large value) to decreasing the input (to display a very small value).

7-2 Calculating the K Factors.

The following steps are the recommended procedure for calculating the K Factors. Take your time and go through the procedure slowly at first. After several tries you should be fairly adept at calculating the K Factor for any given input.

7-2.1 Calculating the K Factor for Digital Pulse Inputs.

Step 1. Find out what value the pulses represent. This should be specified on your device or with its paper work.

Example #1: 360 Pulses = 1 yard

Example #2: 1 Pulse = 2 gallons

Example #3: 2000 Pulses = 1 m³

Step 2. The Count K Factor is equal to the number of pulses per value from Step 1 (Pulses ÷ Value).

Example #1: Count K Factor = 360

Example #2: Count K Factor = 0.5 (1 pulse ÷ 2 gallons)

Example #3: Count K Factor = 2000

Step 3. Enter the Count K Factor. (See Section 3-3, Menu Item 3).

Step 4. Modify the Count K Factor to reflect any time conversions for the rate display to the Rate K Factor. This is done by dividing the Count K Factor by the Time Conversion Factor. If no conversion is necessary skip this step and let the Rate K Factor be the same as the Count K Factor. **USE THE TIME CONVERSION CHART AS NEEDED.**

Example #1: Convert yds per sec to yds per hour.

$$\text{Rate K Factor} = 360 \div 3600 = \underline{0.100}$$

Example #2: Convert gallons per sec to gallons per min.

$$\text{Rate K Factor} = 0.5 \div 60 = \underline{0.00833333}$$

Example #3: No conversion necessary.

$$\text{Rate K Factor} = \underline{2000}$$

Step 5. Enter the Rate K Factor. (See Section 3-3, Menu Item 3)

TIME CONVERSION CHART

To convert:	divide by
sec to min	60.00
sec to hr	3600
min to sec	0.01666667
min to hr	60.00
hr to min	0.01666667
hr to sec	0.0002778

7-2.2 Digital K Factor Formulas

$$\frac{\text{Pulses}}{\text{Units Value}} = \text{Base K Factor}$$

$$\frac{\text{Base K Factor}}{\text{Units Conversion Factor}} = \text{Count K Factor}$$

$$\frac{\text{Count K Factor}}{\text{Time Conversion Factor}} = \text{Rate K Factor}$$

7-2.3 Calculating the K Factor for Analog Inputs.

Step 1. Find out what value the maximum input signal represents. This should be specified on your device or with its paper work.

Example #1: 20 mA = 100 gal / min

Example #2: 5 V = 10 ft / sec

Example #3: 10 V = 32 m³/ hr

Step 2. The Rate K Factor is equal to 10000 divided by the value from Step 1.

Example #1:

$$\text{Base K Factor} = 10000 \div 100 = \underline{100}$$

Example #2:

$$\text{Base K Factor} = 10000 \div 10 = \underline{1000}$$

Example #3:

$$\text{Base K Factor} = 10000 \div 32 = \underline{312.5}$$

Step 3. Enter the Rate K Factor.
(See Section 3-3, Menu Item 3).

Step 4. Modify the Rate K Factor to make the time conversion to seconds for the count display. This is done by dividing the Rate K Factor by the Time Conversion Factor. If no conversion is necessary skip this step and let the Rate K Factor be the same as the Count K- Factor. USE THE TIME CONVERSION CHART AS NEEDED.

Example #1:

Convert pounds per min to pounds per sec

$$\text{Count K Factor} = 100 \div 0.01666667 = \underline{6000}$$

Example #2: No conversion needed.

$$\text{Count K Factor} = \underline{1000}$$

Example #3:

Convert gal per hr to gal per sec.

$$\text{Count K Factor} = 312.5 \div 0.0002778 = \underline{1124910}$$

Step 6. Enter the Count K Factor. (See Section 3-3, Menu Item 3)

7-2.4 Analog K Factor Formulas.

$$\frac{10000}{\text{Maximum Input Signal}} = \text{Rate K Factor}$$

$$\frac{\text{Rate K Factor}}{\text{Time Conversion Factor}} = \text{Count K Factor}$$

Q. Is it possible to count in one system of measurement and display rate in another?

A. Yes, modify the Count K Factor to reflect any units conversions. This is done by dividing the Count K Factor by another Units Conversion Factor. REFER TO THE UNITS CONVERSION CHART AS NEEDED.

UNITS CONVERSION CHART

To convert:	divide by	To convert:	divide by
ft to m	0.3048	kg to lb	2.2046
ft ² to m ²	0.0929	l to ft ³	0.0353
ft ³ to m ³	0.02832	l to gal	0.2642
ft ³ to gal	7.4805	m to ft	3.2808
gal to l	3.7854	m ² to ft ²	10.7639
gal to m ³	0.00379	m ³ to ft ³	35.3147
gal to ft ³	0.1337	m ³ to gal	264.172
gal to lb(H ₂ O)	8.3378	lb to kg	0.45359

7-3 Calculating 16 Point K Factors

Units equipped with the 16 Point option allow the user to enter in from 3 to 16 different frequency points (inputs per second) and assign different K Factor dividers from 0.00011 to 999999 for each of these frequencies. The 16 Point unit determines the incoming frequency and calculates a K Factor line slope from the two closest data points that had been entered. The specific K Factor is then proportionally interpolated using 8 position floating math. This K Factor is applied to all inputs until the next frequency calculation, usually 1 second later. If a 0 frequency is entered into point 1, the point 1 K factor will be applied to all inputs received before the first frequency calculation.

In order to keep track of data, each Frequency / K Factor data entry is assigned a point number. Any point number may be selected to view and / or change the Frequency / K Factor data as long as the frequencies of the ascending point numbers are also entered in ascending frequencies.

7-3.1 Some Notes on 16 Point Setup

- 1) The unit will not accept a K Factor of (0) zero. If a zero is entered the unit automatically puts a (1) one in its place. Division by zero is not allowed.
- 2) Point 01 will be the low shut-off frequency. Below this frequency no rate will be displayed nor count recorded. Point 01 should be assigned a frequency of (0) zero with a K Factor for lowest flow especially if very slow flow is to be counted.
- 3) The entry of a frequency of (0) zero for Point 03 or above will tell the unit to continue the K Factor slope line calculated from the two previous Frequency / K Factor points and ignore any higher point data. If a fixed K Factor is desired, assign the same K Factor to two ascending frequency points and enter a frequency of (0) zero in the next higher point entry.
- 4) Extrapolated K Factors are always positive numbers. Make sure that the last two points do not project the K Factor slope towards zero.
- 5) The dummy decimal point is still set up with DEC LOC menu under DEV TYP. However,

the auto-ranging decimal point in the rate display will be shifted to the left as the dummy decimal is shifted to the left. This is so that the rate display will be as same as the count. For example: The input pulses are coming in at 100 pulses per minute. The decimal point is set at (1) one (DEC LOC). At the end of one minute the count will read 10.0. During the minute the rate will read 10.0 while it would show 100.0 if no decimal point were added.

7-3.2 Test Mode Operation and K Factor Calculation

A special TEST mode can be accessed through the 16 Point setup menu. This is used to help set the points and K Factors as well as calibration of the metering device. If TEST is selected, the K Factor is set to (1) one for all frequencies. Thus, the totalizer will accumulate one count for each incoming pulse. Below are steps for calculating the K Factors with pulsing devices or analog transmitters.

- 1) Set the 16 Point unit to TEST and press ENT on POINT 00 to go to the run mode.
- 2) At the lowest desired flow rate, reset the counter and let the unit count the incoming signal while the rate displayed is recorded.
- 3) Interrupt the input signal when the known tested amount has gone through the metering device. Switch to count display and read the number of counts that came in from the known volume as displayed on the unit. Divide the counts by the volume that passed through the meter to determine the number of counts for 1 unit of measure, gallon, cubic feet, etc.
- 4) Record this frequency and K Factor for later entry into Point 01 or Point 02. (See 7-3.1 Note 2 to determine if the data should be entered in point 1 or 2)
- 5) Assign ascending point numbers to corresponding ascending frequencies when recording Frequency / K Factor data. Repeat process until desired number of points are set up.

SECTION 8 SERIAL COMMUNICATIONS

This section applies to units which have the Serial Communications interface option. Up to 15 units can be linked together. Unit status can be accessed and new set points and K Factors can be entered through the serial port. The unit cannot be taken out of the Run Mode through the serial port. Menu changes must always be made through the front keypad (except Preset, Prewarn, and K Factors). Data is transmitted at selected baud rates using standard seven bit ASCII characters and parity with two additional bits of "Start" and "Stop" to make up the standard ten bit character.

8-1 Unit Code

Each Batcher in the hookup must be assigned a code number from 1 to 15, through the front keypad, in the OUTCARD setup mode (see Section 3-3, Menu Item 5). Number "00" is reserved for a dedicated hookup to only one terminal and its transmit output line remains in an "on" active state. (Units assigned other numbers have outputs that remain in the "off" high impedance state until addressed by their code number or brought on line by a positive edge of the Strobe input). Once a unit is addressed, do not address another unit until the data has been sent and any data requested has been transmitted back.

8-2 Baud Rate

The Baud rate is the speed at which data is transmitted, expressed in bits per second. Baud rates of 300, 600, 1200, 2400, 4800, or 9600 are available. Use the front keypad to call up the OUTCARD setup mode (see Section 3-3, Menu Item 5) and select the desired baud rate that is compatible with the remote terminal.

8-3 Parity

Parity is a bit of information that is inserted before the stop bit and is used to help check if the transmission is correct. In the OUTCARD setup mode, select between:

- a) ODD (Parity bit is logical zero if total number of logical 1's in the first seven bits is odd)
- b) EVEN (Parity bit is logical zero if total number of logical 1's in the first seven data bits is even.)
- c) MARK (Parity data bit is always logical 1.)
- d) SPACE (Parity data bit is always logical 0.)

The Batcher does not check the parity but does transmit the parity chosen.

Idea: Use the MARK parity for terminals that need two stop bits and/or no parity since these terminals ignore the parity anyway.

Note: If the parity of the terminal is not known, it is often practical to key in a different parity until the correct one is found.

8-4 RS232 Electrical Requirements

The Batcher uses standard EIA specifications. Standard inputs must present a load of 3000 to 7000 ohms. A voltage level of +3 V to +25 V (referenced to signal ground) is read as a "Space" or "0" and indicates an active state (asserts a control line). A voltage level of -3 V to -25 V (referenced to signal ground) is read as a "Mark" or "1" and does not indicate an active state (does not assert a control line). Outputs must send a voltage of +5 V to +25 V (referenced to signal ground) for a "Space" and a voltage level of -5 to -25 V for a "Mark" when loaded with a 3000 ohm load to signal ground. Outputs must be capable of being shorted to other signal lines without burning out.

Note: It is normally recommended. that cable length be limited to 50 feet.

8-5 RS232 Card Wiring

This option has a subminiature D, 25 pin, female connector and is wired as a DCE (Data Communications Equipment) device. If it is connected to a DTE (Data Terminal Equipment) device, the interconnect cable should have wires 2 and 3 connected straight to the same pins on each end.

If it is connected to another DCE device, Pins 2 and 3 must be crossed. This means that the wire to pin 2 on one end goes to pin 3 on the other end and the wire to pin 3 on one end goes to pin 2 on the other end.

8-5.1 Wiring Diagram RS232 / Strobe (25 Pin Connector)

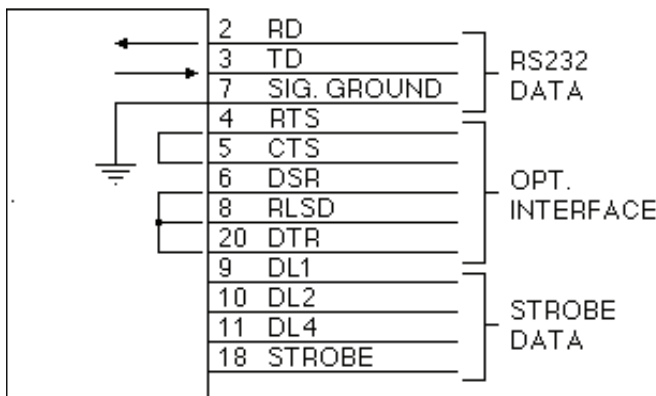

8-5.2 RS232 Wiring Notes

The Batcher requires only three wires for RS232 communication:

- a) Pin 7 (Signal Ground)
- b) Pin 2 (Receive Data)
- c) Pin 3 (Transmit Data)

Other pins are jumped to simulate appropriate responses required for some terminals.

- a) Pin 4 (Request To Send), Pin 5 (Clear To Send). Jumped internally to echo back signals.
- b) Pin 6 (Data Set Ready), Pin 8 (Received Line Signal Detector), Pin 20 (Data Terminal Ready). Jumped internally to echo back signals.

8-6 RS422 Electrical Requirements

The input of the Batcher follows the standard EIA high impedance minimum of 12 K Ohms. When the 422+ (A) input is more positive than the 422- (B) input by 0.2 V to 6 V, a "1" or "Mark" condition is recognized. When the 422+ input is more negative than the 422- input by 0.2 V to 6V, a "0" or "Space" is recognized. Data is recognized by the polarity of the voltage difference between the two lines. Noise picked up in the line will make little difference since the noise is usually added to each line and the voltage differential remains the same. The output driver drives the transmit lines to a differential of 2 to 6 V. It is designed to handle loads up to 60 mA of sink or source current and features positive and negative current conditions. Since the RS422 is more immune to noise, cable links up to 1000 feet or more can be used. Because of the high input impedance of RS422, line terminating loads are recommended. For hook-up to a single unit, a 150 to 200 Ohm resistor across Receive Data+ and Receive Data(-), at the Batcher and at the remote terminal is often sufficient. For multiple hookups, other standard terminations should be used. **Note:** Total loading should not be greater than 90 Ohms.

8-7 RS422 Card Wiring

This option has a subminiature D, 37 pin, female connector and is wired as a DCE (Data Communications Equipment) device. It is designed to be connected to a DTE (Data Terminal Equipment) device. If it must be connected to a DCE device, it will be necessary to cross wires 4 and 6 as well as 22 and 24 at one end of the connector harness.

8-7.1 Wiring Diagram RS422 / Strobe (37 Pin Connector)

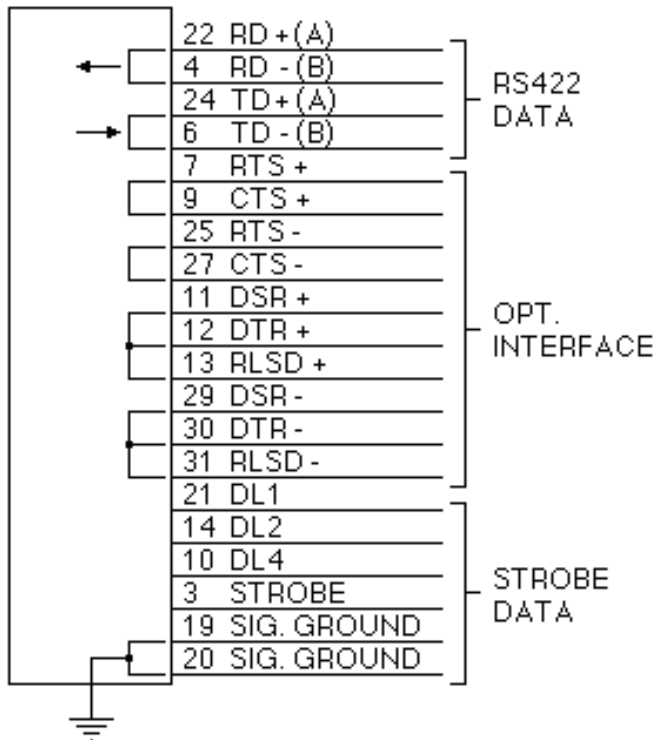

8-7.2 RS422 Wiring Notes

The Batcher requires only four wires for RS422 communication:

- a) Pin 22 (Receive Data +A)
- b) Pin 4 (Receive Data -B)
- c) Pin 24 (Transmit Data +A)
- d) Pin 6 (Transmit Data -B)

Other pins are jumped to simulate appropriate responses required for some terminals.

- a) Pins 7, 25 (Request To Send), Pins 9, 27 (Clear To Send). Jumped internally to echo back signals.
- b) Pins 11, 29 (Data Set Ready), Pins 13, 31 (Received Line Signal Detector), Pins 12, 30 (Data Terminal Ready). Jumped internally to echo back signals.

8-8 Strobe Input Electrical Requirements

Both the RS232 and RS422 interface option cards have inputs that allow data to be requested over a separate strobe input and a 3 bit, data request, code input. Any number of unit's, data request, code lines can be linked in parallel; as long as the source can drive the combined load of all inputs linked together (1.5 K Ohm divided by the total number linked together). Data is transmitted over the serial lines using standard RS232 or RS422 characteristics.

Note: Strobe and data request inputs are positive true with signal ground as reference:

8-8.1 Strobe Input Levels

- 0 or low: Open or 0 to 1 VDC
- 1 or high: 3 to 30 VDC
- Impedance: 1.5 K Ohm

8-9 Strobe Wiring

8-9.1 RS232 Strobe Wiring (RS232, 25 Pin Connector)

The 3 data lines are hooked up to Pins 9, 10, and 11. These lines must be held high while a strobe of at least 25 milliseconds is given on Pin 18. Data is transmitted in RS232 serial format on the Transmit Data Line (Pin 3).

- a) Pin 9, Binary 1's Input
- b) Pin 10, Binary 2's Input
- c) Pin 11, Binary 4's Input
- d) Pin 18, Strobe Input
- e) Pin 3, Transmit Data
- f) Pin 7, Signal Ground for Reference

Refer to 8-5.1 Wiring Hookup RS232 / Strobe (25 Pin Connector) for diagram.

8-9.2 RS422 Strobe Wiring (RS422, 37 Pin Connector)

The 3 data lines are hooked up to Pins 9, 10, and 11. These lines must be held high while a strobe of at least 25 milliseconds is given on Pin 3. Data is transmitted in RS422 format on the Transmit Data Line (Pins 6, 24).

- a) Pin 21, Binary 1's Input
- b) Pin 14, Binary 2's Input
- c) Pin 10, Binary 4's Input
- d) Pin 3, Strobe Input
- e) Pins 6, 24, Transmit Data
- f) Pins 19, 20, Signal Ground for Reference

Refer to 8-7.1 Wiring Hookup RS422 / Strobe (37 Pin Connector) for diagram.

8-10 Serial Interface Operation

Data is received and transmitted over standard EIA RS232 or RS422 levels. To address a Batcher unit, transmit a "D" (device) followed by the 1 to 15 code number and a "Space". Once the space has been received the Batcher becomes active and responds back, "Device XX:" (Device number). (Once active, the unit works in a full duplex echo back mode, so that data sent from the terminal will be transmitted back for verification.) Once the unit is "on line", use the

proper serial transmit codes to request data or set a new value. (See Section 8-10.2 RS232/RS422 Serial Input Codes). Up to 80 characters of data may be linked together and transmitted to the Batcher (as long as there is a space between the different codes). If an error is made, a correction can be made by back spacing and retyping correct data before the "Carriage Return" (Enter) is sent. Once "Carriage Return" (Enter) is sent, the Batcher starts processing the data and will transmit the requested data on a non-priority basis over the data transmit line. A Batcher keypad entry or incoming data will halt the data communication cycle. Therefore, there should be a pause after data is requested to insure that all data has been transmitted before another unit is addressed and brought on line. When transmitting, the Batcher will precede each data value with a "Carriage Return" and "Line Feed" code and answer only with requested data in the order the requests were made. After all requested data has been transmitted any new communication must be started again by DXX (Device number) and space.

8-10.1 Serial Communications Timing.

If the Batcher is not busy, it should not require more than 5 msec to process each request. To find the cycle time to process and transmit a request, calculate the bit transmit time by dividing 1 by the baud rate; multiply that by 80 (8 characters each; 10 bits per character); add 5 msec. to this product and multiply by the number of requests made. Example: Typical time to transmit 1 uninterrupted request at 300 baud rate is $.272 \text{ sec} = (1 \div 300) \times (80) + 0.005$. This time will be extended if the Batcher must service the front keypad or one of the inputs. In practice, if transmission has not started within 2 seconds after data is requested, it can be assumed that there is a problem.

8-10.2 RS232/RS422 Serial Input Codes

DXX(S) (Device and address number followed by space) activates the Batcher that had been assigned that number. That unit comes on line and transmits "Device XX:". Unit is now ready to receive a code or string of codes separated by a space. A "Carriage Return" (Enter) code enters the codes and processing of requests begins.

Note: After device is activated, there must be a delay to allow "Device # _ _" to be transmitted by the unit before any new commands are sent to the unit.

DC	Will transmit Count.
DR	Will transmit Rate.
DT	Will transmit Grand Total.
GO	Will start the unit on a Batch.
KC	Will transmit counter K Factor.*
KC(S)XXX	Will load Counter K Factor number.*
KR	Will transmit Rate K Factor.*
KR(S)XXX	Will load Rate K Factor number.*
PA	Will transmit Preset value.
PA(S)XXX	Will load Preset value number.
PW	Will transmit Prewarn value.
PW(S)XXX	Will load Prewarn value number.
RC	Will reset counter to zero if in "RO" mode (adding) or set counter to Preset value if in "SP" mode (subtracting). Output is reset.
RC(S)XXX	Will set counter to number (no other change is made).
RT	Will reset Grand Total to zero.
RT(S)XXX	Will reset Grand Total to number.
ST	Will stop the unit from the batch in progress.

* See Section 8-10.4 for 16 Point Option data entry commands.

8-10.3 RS232/RS422 Serial Input Examples

Example A: (S) = Space

Transmit from terminal	Receive from Batcher
D13(S) [Unit 13 activated]	Device #13
PA(S)76546(S)PA(S)	PA 76546 PA
KC(S)1575(S)KC(S)	KC 1575 KC
RC(ENTER)	RC

{Preset set to 76546, Count K Factor set to 1575, and Counter is reset.}

Example B: (S) = Space

Transmit from terminal	Receive from Batcher
D7(S) [Unit 7 activated]	Device #7
PA(S)12347(S)PA(S)	PA 12347 PA
RC(S)456789(S)RCC(S)	RC 456789 RC
RT(S)376(S)DT(ENTER)	RT 376 DT

{Batcher Preset set to 12347, Counter set to 456789, and Grand Total set to 376.}

8-10.4 16 Point Data Entry Commands

FA	Will transmit frequency of A (Point 01)
KA	Will transmit K Factor of A (Point 01)
FA(S)XXX	Will load frequency into A (Point 01)
KA(S)XXX	Will load K Factor into A (Point 01)
FB	Will transmit frequency of B (Point 02)
KB	Will transmit K Factor of B (Point 02)
--	(Use letters A to O for Points 01 to 16)
FO	Will transmit frequency of O (Point 16)
KO	Will transmit K Factor of O (Point 16)
FO(S)XXX	Will load frequency into O (Point 16)
KO(S)XXX	Will load K Factor into O (Point 16)

To request a transmit of data, send a code for information desired. To change data, send the desired address code followed by a space and the new number desired.

8-10.5 RS232/RS422 16 Point Serial Input Example

Example : (S) = Space

<u>Transmit from terminal</u>	<u>Receive from Batcher</u>
D11(S) [Unit 7 activated]	Device #11
FC(S)500(S)KC(S)305	FC 500 KC 305
	{Frequency for C (Point 03) is set to 500,}
	{K Factor for C (Point 03) is set to 305.}
FC(S)KC(S)(ENTER)	FC KC
	{Unit echoes back commands as sent.}
Frequency of C is sent	500
K Factor of C is sent	305

8-11 Strobe Address Operation

Another method of reading the status of a unit with either a RS232 or RS422 option is by means of a separate strobe address and a 3 bit data request code. The strobe address method does not allow changes of set points. Theoretically hundreds of units could be linked together to transmit data from the Batchers over a serial transmit line. The units could be assigned any code number except "00". The 3 bit data request code would be latched

in at the positive edge of a 3 to 30 VDC strobe input that remained high a minimum of 25 milliseconds. Requests are processed on a non-priority basis. Normally data will begin to be transmitted from the Batcher over the RS232 or RS422 serial transmit lines within 5 msec unless interrupted by a keypad entry or other signal input.

Note: No other unit should be brought on line until data requested has been transmitted.

Note: There are no allowances for Frequency or K Factor access on units with the 16 Point Option.

8-11.1 Strobe Input Codes

#	DL4	DL2	DL1	Code	Description
0	0	0	0	PA	Will transmit Preset value.
1	0	0	1	PW	Will transmit Prewarn value.
2	0	1	0	KC	Will transmit counter K Factor.
3	0	1	1	KR	Will transmit Rate K Factor.
4	1	0	0	DC	Will transmit Count.
5	1	0	1	DT	Will transmit Grand Total.
6	1	1	0	DR	Will transmit Rate.

9 Programming Worksheet

Model # _____
Serial # _____
Unit # _____

PRESET _____
PREWARN _____
PREset TYPE EZ PRE STD PRE

OUTput FREQuency 20000
 2000
 200
 10

COUNTER

K-FACTOR _____
 Reset to 0 Set to Preset
Decimal Location (0-8)
 8 7 6 5 4 3 2 1 0
 None

Terminals

- 1 - Not Used
- 2 - Scaled Pulse Output O.C.
- 3 - Analog Output
- 4 - Input A (Pulse/Analog)
- 5 - Remote Stop/Reset Input
- 6 - Not Used
- 7 - Not Used
- 8 - Not Used
- 9 - Not Used
- 10 - Remote Start Input
- 11 - Ground (-DC), Input Common
- 12 - Ground (-DC), Input Common
- 13 - +12 Volts Out
- 14 - DC Power In (12 - 27 VDC)
- 15 - Isolate -12 Volts
- 16 - Isolate +12 Volts
- 17 - AC In
- 18 - AC In
- 19 - Prewarn Transistor O.C.
- 20 - Preset Transistor O.C.

RATEmeter

K-FACTOR _____
WINDOW (02-24) __
SIGNificant FIGures (1-6) _
WEIGHT (00-99) __

Lockout Code

SECUR __
CODE ____

Output Communication (If applicable)

UNIT (00-15) __
 Parallel Serial
BAUDRATE 300 2400
 600 4800
 1200 9600
PARITY Space Odd
 Even Mark

Analog Output (If applicable)

Rate Count
SET LOW 4 mA= _____
SET HIGH 20 mA= _____

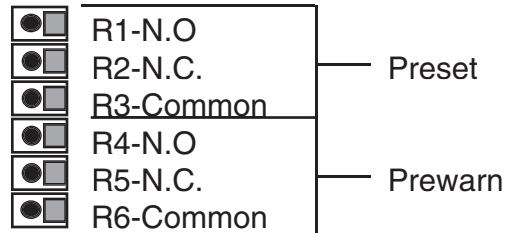

Terminals

- 1 - Not Used
- 2 - Scaled Pulse Output O.C.
- 3 - Analog Output
- 4 - Input A (Pulse/Analog)
- 5 - Remote Stop/Reset Input
- 6 - Not Used
- 7 - Not Used
- 8 - Not Used
- 9 - Not Used
- 10 - Remote Start Input
- 11 - Ground (-DC), Input Common
- 12 - Ground (-DC), Input Common
- 13 - +12 Volts Out
- 14 - DC Power In (12 - 27 VDC)
- 15 - Isolate -12 Volts
- 16 - Isolate +12 Volts
- 17 - AC In
- 18 - AC In
- 19 - Prewarn Transistor O.C.
- 20 - Preset Transistor O.C.

- | | |
|------------------------------------|---------|
| <input type="checkbox"/> R1-N.O | Preset |
| <input type="checkbox"/> R2-N.C. | |
| <input type="checkbox"/> R3-Common | |
| <input type="checkbox"/> R4-N.O | Prewarn |
| <input type="checkbox"/> R5-N.C. | |
| <input type="checkbox"/> R6-Common | |

WARRANTY

This product (excluding batteries) is warranted against defects in materials and workmanship for a period of two (2) years from the date of shipment to Buyer.

The Warranty is limited to repair or replacement of the defective unit at the option of the manufacturer. This warranty is void if the product has been altered, misused, dismantled, or otherwise abused.

ALL OTHER WARRANTIES, EXPRESSED OR IMPLIED, ARE EXCLUDED, INCLUDING BUT NOT LIMITED TO THE IMPLIED WARRANTIES OF MERCHANTABILITY AND FITNESS FOR A PARTICULAR PURPOSE.

Ordering

Decoding Part Number:

Example VA15BT28 A 7AX 2 A 13

Series: _____

VA15BT28 = Batcher

Operating Voltage:

A: 110 VAC ±15% or 12 to 27 VDC

B: 220 VAC ±15% or 12 to 27 VDC

Control Inputs:

* 3A: STD Pulse 3-30 VDC 20 kHz Max.

* 3B: As 3A, with 4.7 KΩ pull up resistors

5A: 4-20 mA

5B: 0-20 mA

5C: 1-5 VDC

5D: 0-5 VDC

5E: 0-10 VDC

6A: 4-20 mA Square Law

7A: 4-20mA in, 4-20mA out

7B: 0-20mA in, 4-20mA out

7C: 1-5VDC in, 4-20mA out

7D: 0-5VDC in, 4-20mA out

7E: 0-10VDC in, 4-20mA out

For Other Outputs:

Add X for 0-20mA out

Add Y for 0-5V out

Add Z for 0-10V out

Control Outputs:

1: Open Collector

2: SPDT Relay 10A

Input Speed:

* A: 0-40 CPS (Inputs 3A, 3B)

* C: 0-400 CPS (Inputs 3A, 3B)

* E: 0-20K CPS (Inputs 3A, 3B)

K: Inputs 5A-5E, 6A, 7A-7E

* Dip switch selectable,

all units can be field modified easily.

Options: (Multiple Options Available)

1: RS232 Serial Interface

2: RS422 Serial Interface

3: 4-20 mA Output (Input 3A or 3B only)

3X: 0-20 mA Output (Input 3A or 3B only)

3Y: 0-5VDC Output (Input 3A or 3B only)

3Z: 0-10VDC Output (Input 3A or 3B only)

4: 16 Point Linearization Opt.

ET: Extended Temperature:

-40° to 158°F (-40° to 70° C)

ET not available with analog inputs or outputs