

VA15

Batch Controller with Large Button



Features

- Start/Stop Buttons & Remote Inputs
- Separate 8 Digit K-Factors For Rate & Total
- Accepts Pulse or Analog Inputs
- Displays Rate, Total and Grand Total
- Security Lockout with Missing Pulse Detection
- Scaled Pulse Output
- Two Way RS232/422 Communications Option
- 2 Setpoints For Two Stage Valve Control
- NEMA 4X (IP65) Front Panel

Description:

Featuring 8 digits of bright, .55 inch, alphanumeric display, the VA15 can accept up to 20,000 pulses per second of digital count. The analog input versions accept inputs, such as 4 to 20 mA or 1 to 5V. The standard unit has two separate, 8 digit, floating decimal, "K" factors to convert the inputs to meaningful total and rate data. An optional 16 point K-factor can linearize flow from non-linear meter outputs. The user, with the push of a button, can toggle back and forth to view the total of the batch, the rate of flow or the grand total of flow.

Specifications:

DISPLAY:

8 Digit, .55" High, 15 Segment, Red Orange, LED.

INPUT POWER: (Internally Fused)

A: 110 VAC $\pm 15\%$ or 12 to 27 VDC

B: 220 VAC $\pm 15\%$ or 12 to 27 VDC

CURRENT:

Maximum 280 mA DC or 5.3 VA (5.3W) at rated AC voltage.

OUTPUT POWER: (On AC powered units only):

+12 VDC at 100mA. Separate Isolated 12 VDC at 100mA to allow +12 VDC or +24 VDC regulated $\pm 5\%$ worst case.

DC Outputs are supplied with resettable fuses.

TEMPERATURE:

Operating: +32°F (0°C) to +130°F (+54°C).

Storage: -40°F (-40°C) to +200°F (+93°C).

ET: Extended Temperature -40° to 158°F (-40° to 70° C)

ET not available with analog inputs or outputs

HUMIDITY: 0-90% Noncondensing

Listing: CE Compliant

MEMORY:

EEPROM stores all program and total data for minimum of 10 years if power is lost.

PULSE INPUTS:

3A: Standard, High impedance pulse input.

Low: Open or 0 to 1 VDC

High: 3 to 30 VDC, 10K Ohm impedance 20 kHz max. input speed (min. on/off 25 μ sec.).

3B: Same as 3A but has 4.7K Ohm input pull up resistors to +5 VDC on input for pulsing with contact to ground or NPN open collector transistor.

ANALOG INPUTS:

The current loop or voltage input is converted to a highly linear 0 to 10 kHz frequency. This frequency can then be scaled by the 8 digit K-Factors to total or display rate in separate engineering units.

Accuracy over full temperature range:

Zero error: +0.175% full scale max.

Overall error: +0.5% full scale max.

5A/7A: 4-20mA, 250 Ohm impedance

5B/7B: 0-20mA, 250 Ohm impedance

5C/7C: 1-5 VDC, 15K Ohm impedance

5D/7D: 0-5 VDC, 15K Ohm impedance

5E/7E: 0-10 VDC, 15K Ohm impedance

6A: 4-20 mA, Square Law, 250 Ohm impedance

RESET:

Front push button: "CLR" resets displayed number and control output.

REMOTE START & STOP/RESET INPUTS:

A 4 to 30VDC positive pulse will activate these inputs. Pin 10 is the START input and when activated, the unit will "start." Pin 5 is the STOP/RESET input. When activated, the unit will "stop" (if unit is started and the batch is not complete). When the unit is stopped or the batch is complete, activating this input will reset the total. If pin 5 is held high (4 to 30VDC), the display will flash "STOPPED" and any start inputs will be inhibited. Stop always over-rides Start input.

NOTE: The remote START input will not work with the type 7 input option (analog in & analog out) boards. All other features will work as described above.

These new features have not yet been added to the 16 point linearization VA15 version 12.0 .

FACTORED OUTPUT:

The BATCHtrol II gives one pulse out for each increment in total. The open collector sinks 30 VDC maximum to 1 volt maximum at 100mA maximum. Output speed is user selectable (see table below). An internal buffer holds up to 10,000 pulses for output at the selected frequency before "DATA LOST" flashes, indicating pulses are lost. If factored rate exceeds 7 digits "RFF..." flashes. These alarms indicated that speed has been exceeded.

SPEED (HZ):	10	200	2000	20000
Min on/off (mSec)	47.5	2.0	0.2	0.013

CONTROL OUTPUTS:

(Each of two outputs)

1. NPN Transistor Version: (Optional)

The open collector sinks max. 250mA from 30 VDC when active. (When relay is used, 10 VDC is provided at transistor outputs through relay coil. If greater than 2mA is used, relay will remain energized. Applying greater than 10 VDC may destroy unit. Transistor will sink 100mA in "ON" state).

2. SPDT Relay Version:

10A 120/240 VAC or 28 VDC (Standard).

ANALOG OUTPUT:

Digital input or analog input (except Square Law) versions can be ordered with an analog output of the rate or total reading. User keys in the low and high settings at set-up.

Current Outputs:

A sinking driver generates a corresponding linear current through the external devices, updating with each update of the rate. Accuracy is ±.5% FS worst case. Compliance voltage must be 3 to 24 VDC, non inductive. (The BATCHtrol II can provide the DC source as long as the drop across all devices being driven does not exceed 21 V).

Voltage Outputs:

When the voltage out option is ordered, a controlled voltage output is located at terminal 3 and referenced to pin 12 (ground). Accuracy is .1% @ 20°C (max. drift .01%/C°).

SECURITY:

The BATCHtrol II has a missing pulse detector. The user selects the amount of time (1 to 99 sec.) that the unit will "wait" for input pulses. If the unit doesn't receive pulses within the selected time, the unit displays "SECURITY" and both relays drop out. (00 Disables the security feature; Entering the lockout code returns the unit to the run mode)

PRESETS:

The user may enter two numbers to set up the batch totalizer, Preset and Prewarn. The Prewarn is a number set a certain amount before the preset number. For instance, you may want one hundred gallons in a particular batch. You may also want a valve to close and slow down flow 25 gallons before the end. Your preset is 100, your prewarn is 25. When the start is activated, the relays energize simultaneously to start flow. When the totalizer reaches 75, the prewarn relay drops out. When the totalizer reaches 100 the preset relay drops out. The preset values can be viewed or changed via the menu (when stopped).

K-FACTOR:

In the standard unit a fixed K-Factor is used to convert the input pulses or frequency generated internally by the analog input to engineering units. The 8 digit K-Factor dividers, with decimal keyed into any position, allow easy direct entry of any K-Factor greater than 0.0001 to 99999999. Separate K-Factors may be entered for the total and rate section. Thus, you may batch and total in gallons and display rate in liters per hour.

16 POINT LINEARIZATION:

This variable K-factor option makes flow systems more accurate and often extends their usable range by allowing users to dial in different K-factors for different flow rates. It works with either pulse input or standard analog current loop or voltage input. It is recommended for flow meters whose K-factors change with different rates of flow. From 3 to 16 points of frequency from 0 to 10,000 Hz. and K-factors greater than .0001 to 999,999 are dialed in at set up. The 16 point linearization option uses 8 digit floating math to interpolate between settings. Rate per second, per minute or per hour programmability eliminates the need to calculate separate K-factors for total and rate.

TOTALIZER:

Each of the total and grand total counters have 8 digits. In the set-up mode choose "RO" (reset to zero) for adding operation or "SP" (set to preset) for subtracting operation. While viewing the total the display can be made to flash the grand total by pressing "ENT". Activating "CLR" while the grand total is flashing, resets the grand totalizer.

RATEMETER:

Accurate to 5 1/2 digits (±1 display digit). The rate meter can be programmed to accept almost any number of pulses per unit of measurement, sample from 2 to 24 seconds maximum, and autorange up to 6 digits of significant information. The rate meter with a "K" factor of 1 displays the rate of pulses per second. Simply dial in the proper "K" factor to display in minutes, hours or other units of measurement. (See 16 Point Opt. Above) Press the "C" button while the unit is displaying the batch to display the rate; "R" is displayed on the left side of the display.

WEIGHT:

This feature is used to provide a weighted averaging of the rate data being received. Higher settings provide more averaging for a more stable display, derived from the equation:

$$\frac{(\text{Old Data} \times \text{"Weight"} + \text{New Data})}{(\text{"Weight"} + 1)}$$

LOCKOUT:

Unauthorized front panel changes can be prevented by entering a user selected four digit code.

OUTCARD:

RS232 or RS422 serial two way communication options are available. Up to 15 units can be linked together and addressed separately to transmit unit status or accept new set points in the standard ASCII format. Baud rates of 300, 600, 1200, 2400 4800 or 9600 as well as choice of odd, even, space or mark parity can be selected by keypad control.

TERMINATION:

- 1 - Not Used
- 2 - Scaled Pulse Output O.C.
- 3 - Analog Output
- 4 - Input A (Pulse/Analog)
- 5 - Remote Stop/Reset Input
- 6 - Not Used
- 7 - Not Used
- 8 - Not Used
- 9 - Not Used
- 10 - Remote Start Input
- 11 - Ground (-DC), Input Common
- 12 - Ground (-DC), Input Common
- 13 - +12 Volts Out
- 14 - DC Power In (12 - 27 VDC)
- 15 - Isolate -12 Volts
- 16 - Isolate +12 Volts
- 17 - AC In
- 18 - AC In
- 19 - Prewarn Transistor O.C.
- 20 - Preset Transistor O.C.

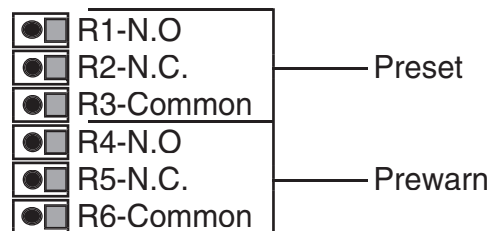

Typical Hookup:

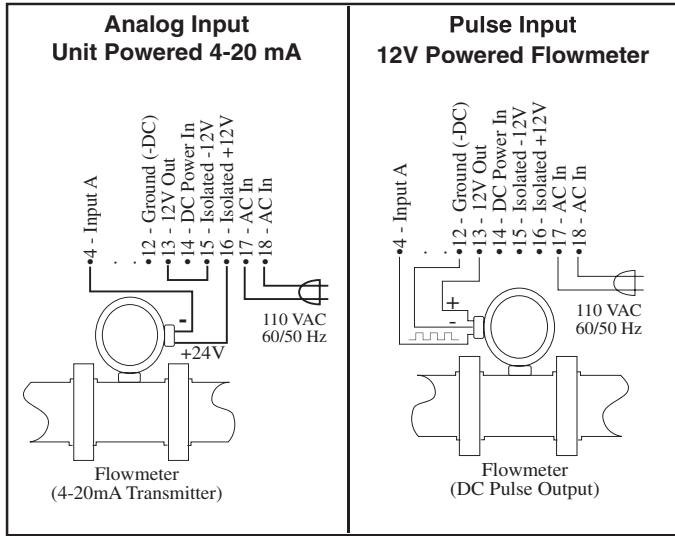

Dimensions:

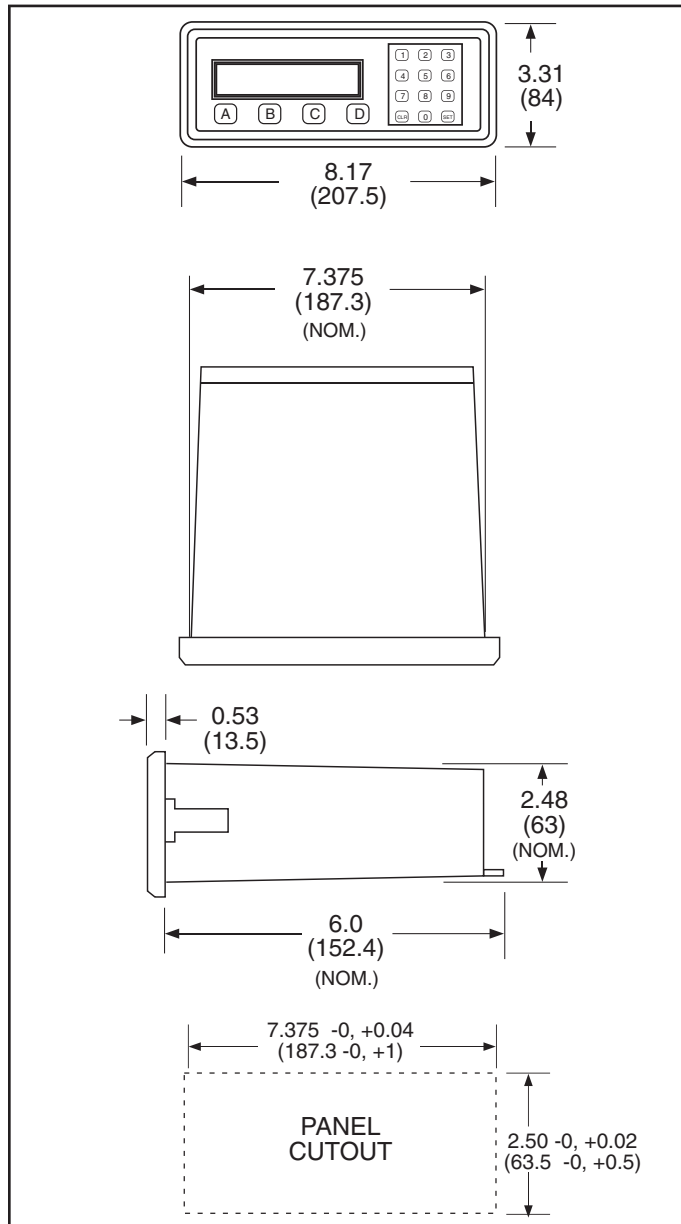

Ordering Information

Example VA15BT28 A 7AX 2 A 1 3

Series:
 VA15BT28 = Batcher

Operating Voltage:
 A: 110 VAC ±15% or 12 to 27 VDC
 B: 220 VAC ±15% or 12 to 27 VDC

Control Inputs:
 * 3A: STD Pulse 3-30 VDC 20 kHz Max.
 * 3B: As 3A, with 4.7 KΩ pull up resistors
 5A: 4-20 mA
 5B: 0-20 mA
 5C: 1-5 VDC
 5D: 0-5 VDC
 5E: 0-10 VDC
 6A: 4-20 mA Square Law
 7A: 4-20mA in, 4-20mA out
 7B: 0-20mA in, 4-20mA out
 7C: 1-5VDC in, 4-20mA out
 7D: 0-5VDC in, 4-20mA out
 7E: 0-10VDC in, 4-20mA out

For Other Outputs:
 Add X for 0-20mA out
 Add Y for 0-5V out
 Add Z for 0-10V out

Control Outputs:
 1: Open Collector
 2: SPDT Relay 10A

Input Speed:
 * A: 0-40 CPS (Inputs 3A, 3B)
 * C: 0-400 CPS (Inputs 3A, 3B)
 * E: 0-20K CPS (Inputs 3A, 3B)
 K: Inputs 5A-5E, 6A, 7A-7E

* Dip switch selectable,
 all units can be field modified easily.

Options: (Multiple Options Available)
 1: RS232 Serial Interface
 2: RS422 Serial Interface
 3: 4-20 mA Output (Input 3A or 3B only)
 3X: 0-20 mA Output (Input 3A or 3B only)
 3Y: 0-5VDC Output (Input 3A or 3B only)
 3Z: 0-10VDC Output (Input 3A or 3B only)
 4: 16 Point Linearization Opt.
 ET: Extended Temperature:
 -40° to 158°F (-40° to 70° C)
 ET not available with analog inputs or outputs

KROHNE

USA

KROHNE Inc.
 7 Dearborn Road
 Peabody, MA 01960
 TEL.: +1-978 535-6060
 FAX: +1-978 535-1720
 e-mail: krohne@krohne.com